

WM series

SUSPENSION BRACKET

How to install

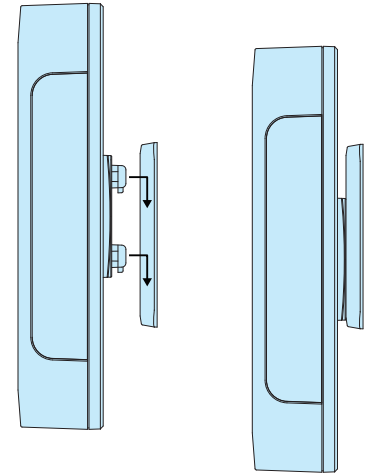

- Plastic wall mounting bracket. Easy attachment and removal.
- Large and small bracket types are available.
- Applicable to be used on plastic or metallic enclosures with a panel thickness of 0.8 ~ 3.5mm.
- To attach the suspension hook onto the enclosure, hole milling is required.
- Please be aware of the insertion direction of the suspension hook against the mounting base when attaching.

Technical Data	
Max load : 2 kg - WM-1	5 kg - WM-2

*The max load values listed are static load values only. Use caution when handling.

WM dimensions

WM-1

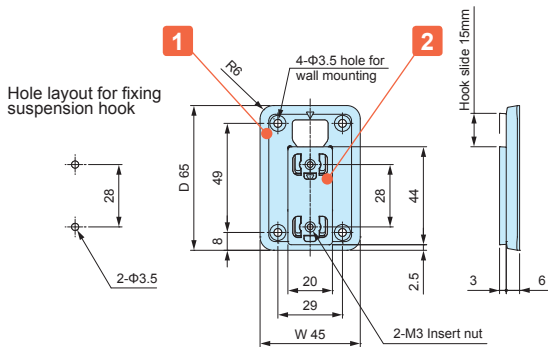

WM-2

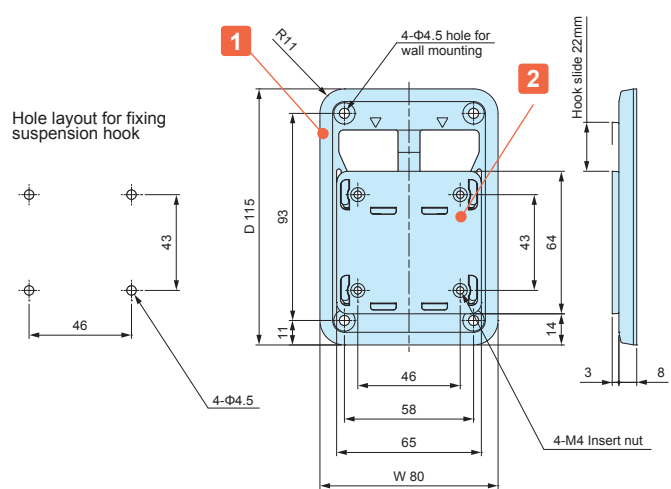

■ DXF/DWG/PDF/STP drawings available on our website.

Components

No.	Part name	Pcs	Material	Color / Finish
1	Mounting base	1	PC + ABS UL94HB	Off-white • Dark gray
2	Suspension hook	1	PC + ABS UL94HB	Off-white • Dark gray
-	Screw	2 (WM-1) 4 (WM-2)	Steel	Nickel plated

Included Screw WM-1 □ : Bind M3-8
WM-2 □ : Bind M4-8

Product no. / Dimensions

Product no.		W	D	Mountable thickness	Weight (g)
● Off-white	● Dark gray				
WM-1W	WM-1D	45	65	t0.8 ~ t3.5	11.5
WM-2W	WM-2D	80	115	t0.8 ~ t3.5	48