

WGF series

WALL MOUNTING BRACKET for WG • WGV

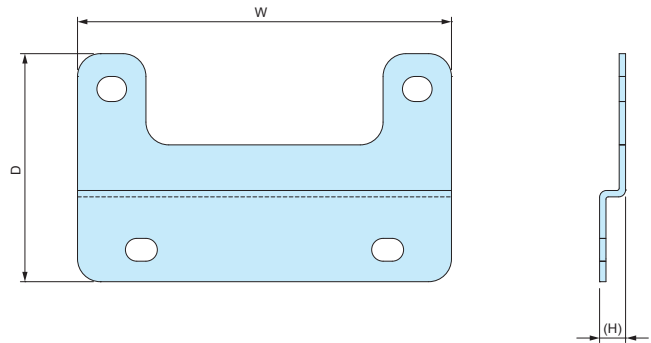

WGF dimensions



- DXF/DWG/PDF/STP drawings available on our website.
- Stainless steel mounting screws included.

Product no. / Details

Product no.	W	D	(H)	Suitable models	Material / Finish	Pack of
WGF-10	82	50	(5.8)	WG • WGV10-15-□ (W direction)	Stainless steel t=1.5mm / Barrel finish	2
WGF-15	132	50	(5.8)	WG • WGV10-15-□ (D direction) WG • WGV15-21-□ (W direction) WG • WGV15-16-□ (W • D direction)		2
NEW WGF-23	184	55	(8.0)	WG • WGV15-21-□ (D direction), WG • WGV23-25-□ (W direction)		2
NEW WGF-25	210	55	(8.0)	WG • WGV17-25-□ (D direction), WG • WGV23-25-□ (D direction)		2

WGMB series

POLE MOUNTING BRACKET for WG • WGV



WGMB dimensions

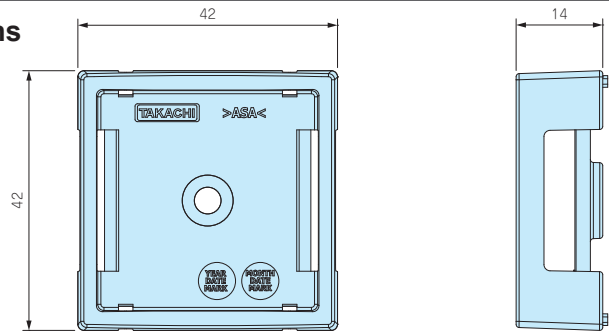

- Pole mount bracket made from weather resistant ASA material.
- Hole milling is not required when installing the mount bracket, thus allowing the enclosure to maintain its IP rating.
- WG • WGV10-15-□ and 15-16-□ can be installed in both the W or D direction.
- Pole mount is possible with the use of SNB or PKB series mounting belt. (See page 323 ~ 324)
- DXF/DWG/PDF/STP drawings available on our website.

Product no. / Details

Product no.	Suitable models	Material / Color	Weight (g)	Pack of
WGMB-1W	WG • WGV10-15-□ WG • WGV15-16-□ (1 pc required) WG • WGV15-21-□ (2 pcs required)	ASA UL94-HB / Off-white	9	1

Installation example

Installation (1 pc)

Installation (2 pcs)

