

UCC series

MOUNTING PLATE for UC

■ DXF/DWG/PDF drawings available on our website.

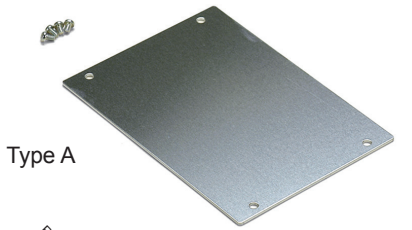

Type A

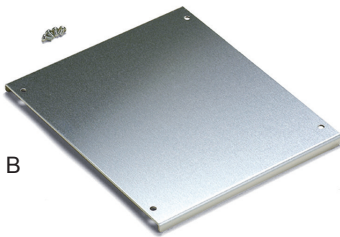
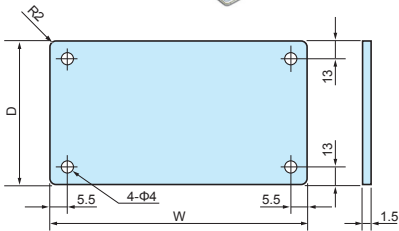

Type B

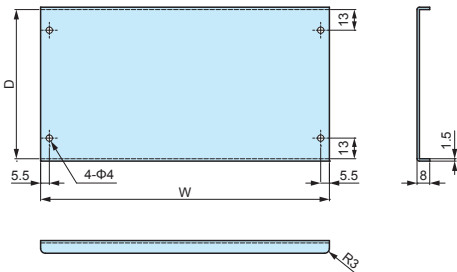

Type C

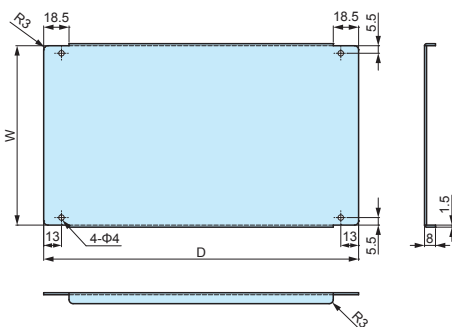

Components

Part name	Pcs	Material	Color / Finish
Mounting plate	1	Aluminium A1050P t=1.5	Unfinished
Screw	4	Steel M3-5	Trivalent chromate

Product no. / Dimensions (Type A)

Product no.	Suitable models	W	D
UCC 6- 8	UC 6- 3- 8	43	58
UCC 7-10	UC 7- 3-10	58	78
UCC 8- 6	UC 8- 3- 6	63	38
UCC11- 8	UC 11- 3- 8	93	58
	UC 11- 5- 8		
UCC 9-12	UC 9- 5-12	72	94
UCC10-14	UC 10- 4-14	82	94
UCC12-16	UC 12- 7-16	101	110
UCC13-18	UC 13- 4-18	111	130
UCC15-20	UC 15- 8-20	131	150
	UCG15- 9-20		
UCC14-10	UC 14- 4-10	123	78
	UC 14- 6-10		
UCC15-12	UC 15-10-12	132	94
UCC17-12	UC 17- 5-12	152	94
	UC 17- 7-12		
UCC 7-14	UC 7- 8-14	57	94
UCC10-18	UC 10-11-18	81	130
UCC12-22	UC 12-14-22	101	170

Product no. / Dimensions (Type B)

Product no.	Suitable models	W	D
UCC16-22	UC 16- 5-22	146	170
UCC18-24	UC 18-10-24	161	190
	UCG18-10-24		
UCC20-14	UC 20- 5-14	182	94
	UC 20- 8-14		
	UCG20- 9-14		
UCC22-26	UC 22-12-26	201	210
UCC20-16	UC 20-12-16	181	110
UCC26-18	UC 26- 5-18	241	130
	UC 26-10-18		
	UCG26-10-18		
UCC26-20	UC 26- 7-20	241	150
UCC32-22	UC 32- 5-22	301	170
	UC 32-12-22		
	UCG32-12-22		
UCC32-24	UC 32- 8-24	301	190
UCC35-26	UC 35-13-26	331	210
UCC43-28	UC 43- 5-28	411	230
	UC 43-14-28		

Product no. / Dimensions (Type C)

Product no.	Suitable models	W	D
UCC15-28	UC 15-18-28	131	230
UCC18-34	UC 18-21-34	160.6	290
UCC24-34	UC 24-14-34	220.6	290

UCK-P series MOUNTING BRACKET for UC



Components

Product name	Material	Finish	Pack of
Mounting bracket	Steel SPCC t=1.6	Trivalent chromate	4

Product no. / Dimensions

Product no.	Type	H1	C	C1	C2	Pack of
UCK-P 13	A	13	3	—	—	4
UCK-P 17	A	17	7	—	—	4
UCK-P 27	B	27	12	17	—	4
UCK-P 42	C	42	22	27	32	4
UCK-P 57	C	57	37	42	47	4
UCK-P 72	C	72	52	57	62	4
UCK-P 87	C	87	67	72	77	4
UCK-P102	C	102	82	87	92	4

■ DXF/DWG/PDF drawings available on our website.

UCK-P assembly drawings

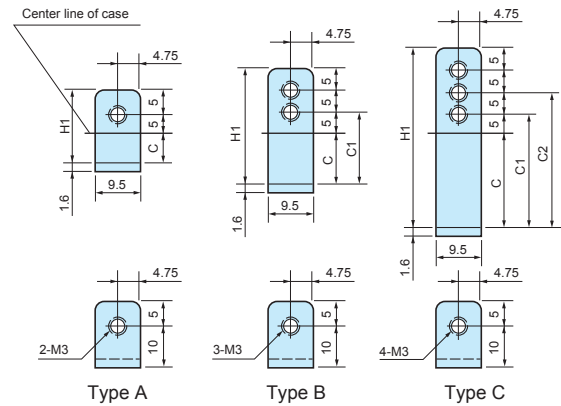
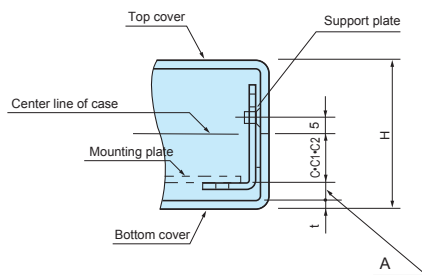

Bracket matching chart / A dimension

Product no.	Bracket no.	A	Product no.	Bracket no.	A	Product no.	Bracket no.	A
UC 6- 3- 8	UCK-P 13	12.5	UC 14- 4-10	UCK-P 13	15	UCG 26-10-18	UCK-P 42	20 15
	UCK-P 17	8.5		UCK-P 17	11		UCK-P 57	10
UC 7- 3-10	UCK-P 13	10	UC 14- 6-10	UCK-P 27	6	UCG 26- 7-20	UCK-P 27	15
	UCK-P 17	6		UCK-P 42	16 11		UCK-P 42	10
UC 9- 5-12	UCK-P 17	15.5	UC 15- 9-20	UCK-P 42	6	UC 18-10-24	UCK-P 42	20 15
	UCK-P 27	10.5 5.5		UCK-P 57	10		UCK-P 57	10
UC 10- 4-14	UCK-P 13	14.5	UC 15-10-12	UCK-P 42	20.5 15.5	UCG 18-10-24	UCK-P 57	10
	UCK-P 17	10.5		UCK-P 57	10.5 5.5		UCK-P 57	20 15 10
UC 12- 7-16	UCK-P 27	5.5	UC 17- 5-12	UCK-P 17	15.5	UC 32- 5-22	UCK-P 13	19
	UCK-P 42	15		UCK-P 27	10.5 5.5		UCK-P 17	15
UC 13- 4-18	UCK-P 13	14	UC 17- 7-12	UCK-P 42	15.5	UC 32-12-22	UCK-P 27	10
	UCK-P 17	10		UCK-P 42	10.5 5.5		UCK-P 57	20 15 10
UC 15- 8-20	UCK-P 42	15 10 5	UC 20- 5-14	UCK-P 13	19.5	UC 32-12-22	UCK-P 57	20 15 10
	UCK-P 13	19		UCK-P 17	15.5		UCK-P 42	15 10 5
UC 16- 5-22	UCK-P 17	15	UC 20- 8-14	UCK-P 27	10.5 5.5	UC 32- 8-24	UCK-P 57	25 20 15
	UCK-P 27	10		UCK-P 42	15.5		UCK-P 72	10 5
UC 24-14-34	UCK-P 57	19.8	UCG 20- 9-14	UCK-P 13	19.5	UC 43- 5-28	UCK-P 13	19
	UCK-P 72	14.8 9.8		UCK-P 17	15.5		UCK-P 17	15
UC 8- 3- 6	UCK-P 13	10	UC 20-12-16	UCK-P 27	20.5	UC 43-14-28	UCK-P 27	10
	UCK-P 17	6		UCK-P 42	15.5 10.5		UCK-P 57	20
UC 11- 3- 8	UCK-P 17	6	UCG 20-12-16	UCK-P 42	5	UC 7- 8-14	UCK-P 72	15 10
	UCK-P 27	16		UCK-P 57	20 15 10		UCK-P 42	18 13 8
UC 11- 5- 8	UCK-P 13	10	UC 26- 5-18	UCK-P 13	19	UC 10-11-18	UCK-P 57	15 10 5
	UCK-P 17	6		UCK-P 17	15		UCK-P 72	15 10 5
UC 11- 5- 8	UCK-P 27	11 6	UC 26- 5-18	UCK-P 27	10	UC 15-18-28	UCK-P 87	20 15 10
	UCK-P 42	15 10 5		UCK-P 42	15 10 5		UCK-P 102	19.8 14.8 9.8

UCF-26 PANEL RETAINER for UC

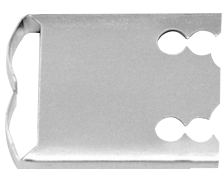

UCF-26 drawings

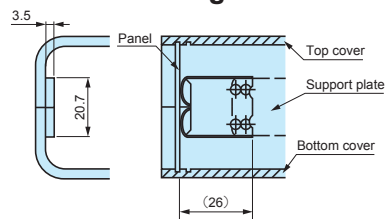

■ DXF/DWG/PDF drawings available on our website.

Product no.

Product no.	Material	Finish	Pack of
UCF-26	Stainless steel t=0.3	Unfinished	2

■ Not applicable for use on 60, 80, 100 and 120 "D" dimension cases.