



- Selectable in 19 different Width / Height types, with adjustable length (depth) in 1mm intervals from 40 to 500mm (80 to 500mm for flanged type).
N (no flange type) and F (flange type) are available.
- Custom sized aluminium enclosure equipped with a highly efficient heat-sink top cover.
- Suitable to be used as a fanless PC, power amplifier, power supply etc., where heat dissipation is required.



- Each heat-sink fin is constructed in a wave-like shape to maximize the heat dissipation effect.

EXHS N Type • F Type (W = 141mm or smaller)

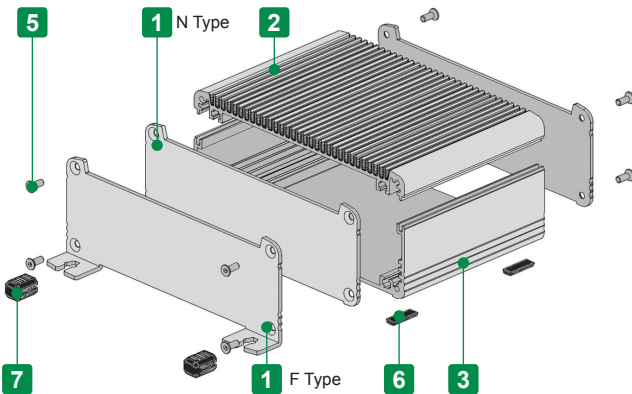

EXHS F Type (W = 187mm or larger)

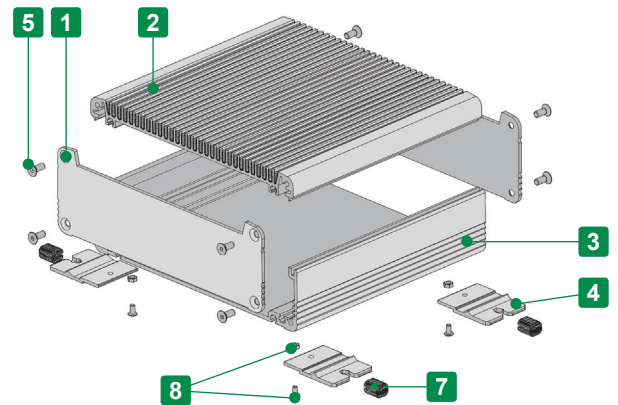

Components

| No. | Part name | Pcs | Material | Color / Finish |
|-----|---|-----|---------------------------------|--|
| 1 | Panel (N Type • F Type - W = 187mm or larger) Flange panel (F Type - W = 141mm or smaller) | 2 | Aluminium A1050P | Metallic silver / Painted (Unfinished inside) : Black / Anodized |
| 2 | Heat-sink top cover | 1 | Extruded aluminium A6063S-T5 | Metallic silver / Painted : Black / Anodized |
| 3 | Bottom frame | 1 | Extruded aluminium A6063S-T5 | Metallic silver / Painted : Black / Anodized |
| 4 | Flange bracket (F Type - W = 187mm or larger) | 4 | Extruded aluminium A6063S-T5 | Metallic silver / Painted : Black / Anodized |
| 5 | Panel screw (Hexagonal) | 8 | Stainless steel | Unfinished |
| 6 | Rubber feet (N Type only) | 4 | Polyurethane • Synthetic rubber | Black |
| 7 | Rubber feet Insert (F type only) | 4 | Silicone | Black |
| 8 | Flange screw & nut (F Type - W = 187mm or larger) | 4 | Steel | Black trivalent chromate |

- See page EXHS-4 ~ EXHS-6 for Heat-sink top cover / Bottom frame dimensions.
- Rubber feet material : Polyurethane : EXHS81-31-□ ~ 187-107-□ models • Synthetic rubber : EXHS232-52-□ ~ 288-128-□ models.

Product Number

To determine the product number, fill in the □ with detail **1** ~ **3** on page EXHS-2.

Product no. **EXHS** - -

1 W-H **1** D length **2** Flange type **3** Color type

Example : W-H = 106-46.4 , D = 123 mm, no flange type, and S color.

EXHS 106 - 46 - 123 N S

1 Dimensions

Width-Height dimension

N No flange type

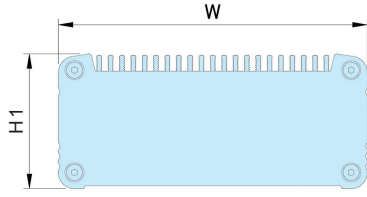

F Flanged type (187-□, 232-□, 288-□)



F Flanged type (81-□, 106-□, 141-□)

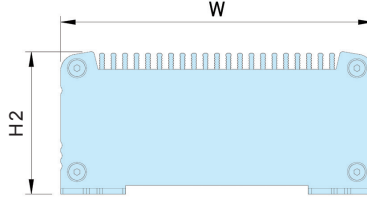

To select a Width-Height dimension number from the table below.

| W-H No. | W | H1 | H2 |
|--------------------|-------|-------|------|
| 81- 31 | 80.6 | 30.7 | 32.8 |
| 81- 41 | 80.6 | 40.7 | 42.8 |
| 81- 56 | 80.6 | 55.7 | 57.8 |
| 106- 31 | 106 | 31.1 | 33.1 |
| 106- 46 | 106 | 46.1 | 48.1 |
| 106- 61 | 106 | 61.1 | 63.1 |
| 141- 36 | 141 | 36.1 | 38.1 |
| 141- 51 | 141 | 51.1 | 53.1 |
| 141- 71 | 141 | 71.1 | 73.1 |
| 141- 91 | 141 | 91.1 | 93.1 |
| 187- 44 | 186.5 | 43.5 | 73.1 |
| 187- 62 | 186.5 | 61.5 | — |
| 187- 82 | 186.5 | 81.5 | — |
| 187-107 | 186.5 | 106.5 | — |
| 232- 52 | 232 | 52 | — |
| 232- 77 | 232 | 77 | — |
| 232-102 | 232 | 102 | — |
| NEW 288- 78 | 287.5 | 77.5 | — |
| NEW 288-128 | 287.5 | 127.5 | — |

■ **N** (No flange type) and **F** (Flanged type) is selectable. Refer to **2** Flange selection below.

D length

D length 40 ~ 500mm (1mm intervals)

※F type (W 187mm or larger) 80 ~ 500mm

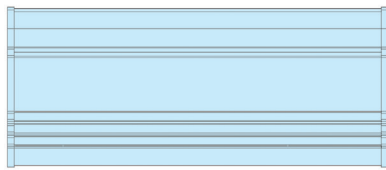

Heat-sink top cover / Bottom frame length ℓ

D length 40 ~ 500mm (1mm intervals)

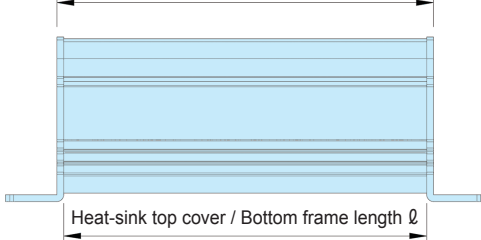

Heat-sink top cover / Bottom frame length ℓ

To specify D length in 1mm interval between 40 ~ 500 mm.

N No flange type

F Flanged type (187-□, 232-□, 288-□)

| W-H No. | ℓ |
|---------|-----|
| 81-□ | D-4 |
| 106-□ | D-4 |
| 141-□ | D-4 |
| 187-□ | D-5 |
| 232-□ | D-6 |
| 288-□ | D-6 |

■ Both panel thickness added on
Top cover/Bottom frame length is D length.

F Flanged type (81-□, 106-□, 141-□)

■ D length can be specified in 0.1mm intervals with cutting tolerances at ±0.3mm.
Cutting tolerance for 1.0 mm intervals shall be ±0.2mm.

■ See page EXHS-4 ~ EXHS-6 for detail dimensions

2 Flange

To select a flange type from the 2 types below.

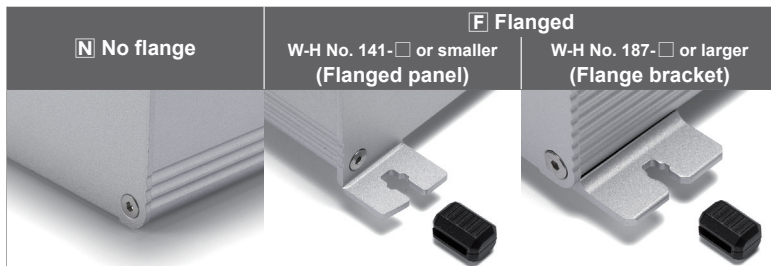

3 Color

To select a color type from the 2 combinations below.

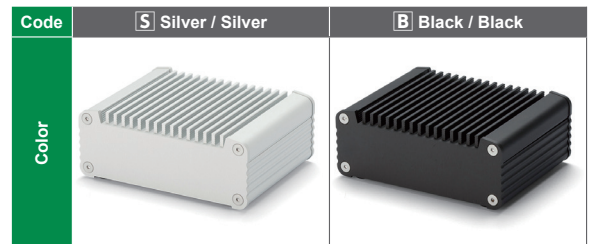

Lead Time

Custom Size Only
Custom Size + Hole Milling

10 business days (1 ~ 10 pcs)
15 business days (1 ~ 10 pcs)

Order Inquiry

For more information, contact us here at sales@takachi-el.co.jp

EXHS dimensions

■ DXF/DWG/PDF drawings available on our website.

EXHS N type / F type (187-□ • 232-□ • 288-□)
 ※No flange bracket comes with N type.

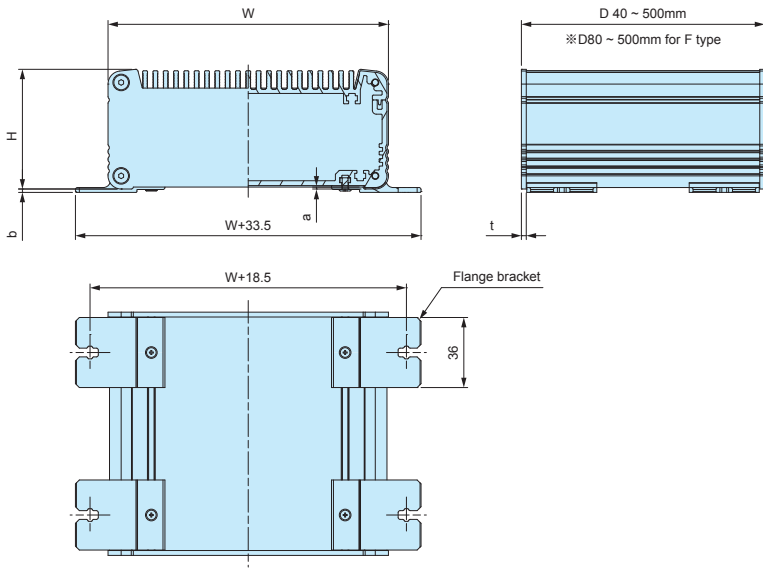

| Product no. | W | H | a | b | t |
|---------------|-------|-------|-----|------|-----|
| EXHS 81- 31-□ | 80.6 | 30.7 | 0.9 | — | 2 |
| EXHS 81- 41-□ | 80.6 | 40.7 | 0.9 | — | 2 |
| EXHS 81- 56-□ | 80.6 | 55.7 | 0.9 | — | 2 |
| EXHS106- 31-□ | 106 | 31.1 | 1 | — | 2 |
| EXHS106- 46-□ | 106 | 46.1 | 1 | — | 2 |
| EXHS106- 61-□ | 106 | 61.1 | 1 | — | 2 |
| EXHS141- 36-□ | 141 | 36.1 | 1 | — | 2 |
| EXHS141- 51-□ | 141 | 51.1 | 1 | — | 2 |
| EXHS141- 71-□ | 141 | 71.1 | 1 | — | 2 |
| EXHS141- 91-□ | 141 | 91.1 | 1 | — | 2 |
| EXHS187- 44-□ | 186.5 | 43.5 | 1 | 1.75 | 2.5 |
| EXHS187- 62-□ | 186.5 | 61.5 | 1 | 1.75 | 2.5 |
| EXHS187- 82-□ | 186.5 | 81.5 | 1 | 1.75 | 2.5 |
| EXHS187-107-□ | 186.5 | 106.5 | 1 | 1.75 | 2.5 |
| EXHS232- 52-□ | 232 | 52 | 1 | 1.5 | 3 |
| EXHS232- 77-□ | 232 | 77 | 1 | 1.5 | 3 |
| EXHS232-102-□ | 232 | 102 | 1 | 1.5 | 3 |
| EXHS288- 78-□ | 287.5 | 77.5 | 1 | 1.25 | 3 |
| EXHS288-128-□ | 287.5 | 127.5 | 1 | 1.25 | 3 |

EXHS F type (81-□ • 106-□ • 141-□)

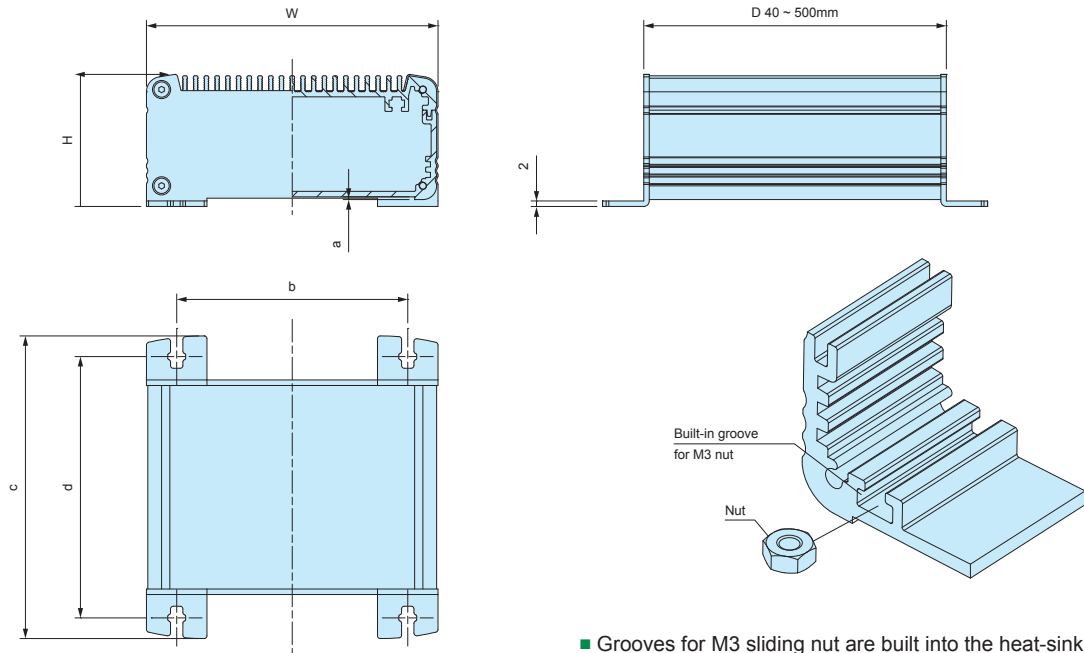

Included screws
 EXHS81-□ models : M2.5-8x8pcs
 EXHS106-□,141-□ models : M3-8x8pcs
 EXHS187-□ models : M4-10x8pcs
 EXHS232-□, 288-□ models : M5-10x8pcs
 ※Hexagonal wrench included.

■ Grooves for M3 sliding nut are built into the heat-sink top cover and bottom frame (140mm or wider).
 Optional nut is available.

| Product no. | W | H | a | b | c | d |
|----------------|------|------|-----|------|------|------|
| EXHS 81- 31-□F | 80.6 | 32.8 | 0.9 | 62.6 | D+30 | D+15 |
| EXHS 81- 41-□F | 80.6 | 42.8 | 0.9 | 62.6 | D+30 | D+15 |
| EXHS 81- 56-□F | 80.6 | 57.8 | 0.9 | 62.6 | D+30 | D+15 |
| EXHS106- 31-□F | 106 | 33.1 | 1 | 84 | D+32 | D+17 |
| EXHS106- 46-□F | 106 | 48.1 | 1 | 84 | D+32 | D+17 |
| EXHS106- 61-□F | 106 | 63.1 | 1 | 84 | D+32 | D+17 |
| EXHS141- 36-□F | 141 | 38.1 | 1 | 119 | D+32 | D+17 |
| EXHS141- 51-□F | 141 | 53.1 | 1 | 119 | D+32 | D+17 |
| EXHS141- 71-□F | 141 | 73.1 | 1 | 119 | D+32 | D+17 |
| EXHS141- 91-□F | 141 | 93.1 | 1 | 119 | D+32 | D+17 |

Cross-section view of heat-sink top cover & bottom frame

■ DXF/DWG/PDF drawings available on our website.

EXHS81-31-□

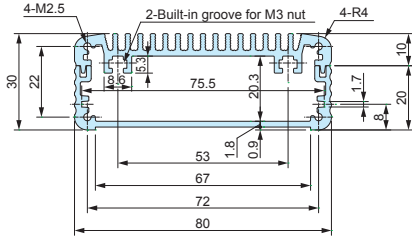

EXHS81-41-□

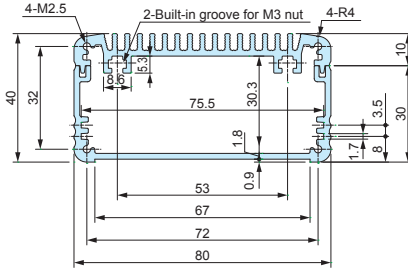

EXHS81-56-□

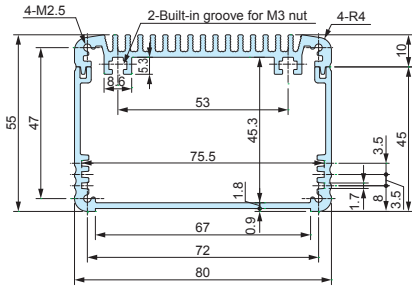

EXHS106-31-□

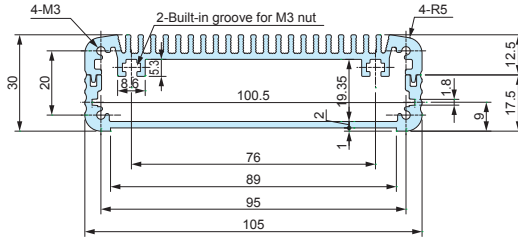

EXHS106-46-□

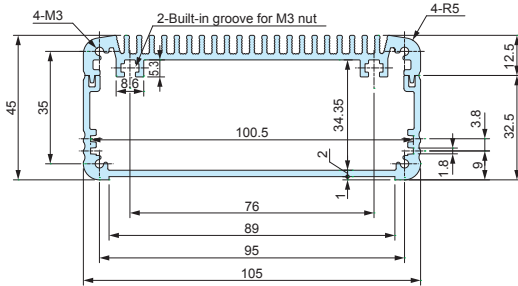

EXHS106-61-□

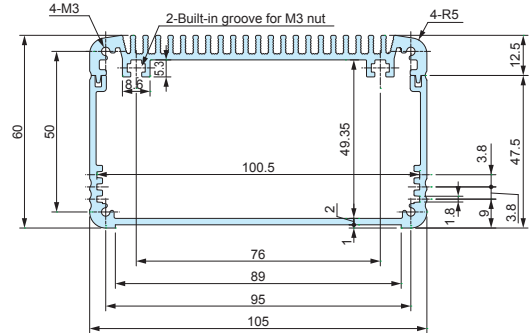

EXHS141-36-□

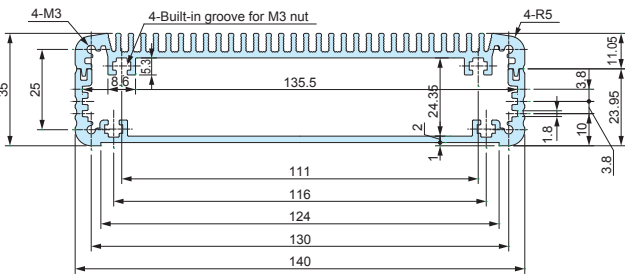

EXHS141-51-□

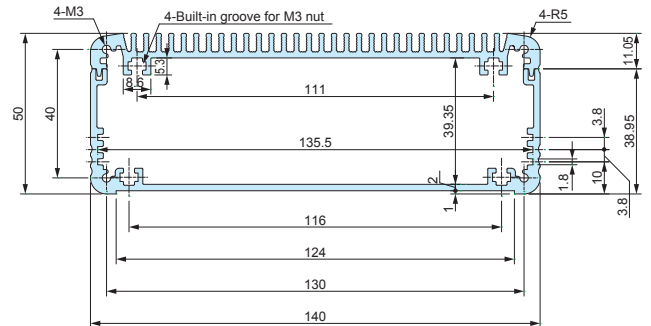

EXHS141-71-□

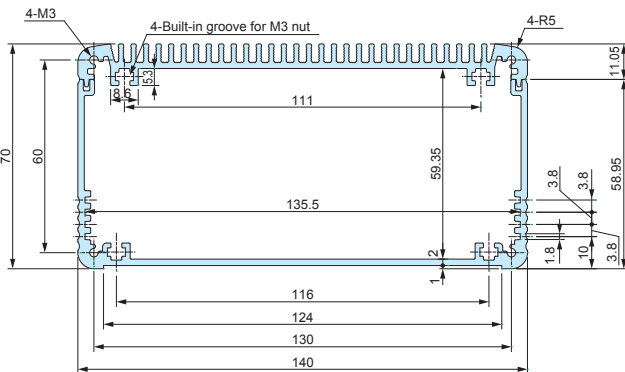

EXHS141-91-□

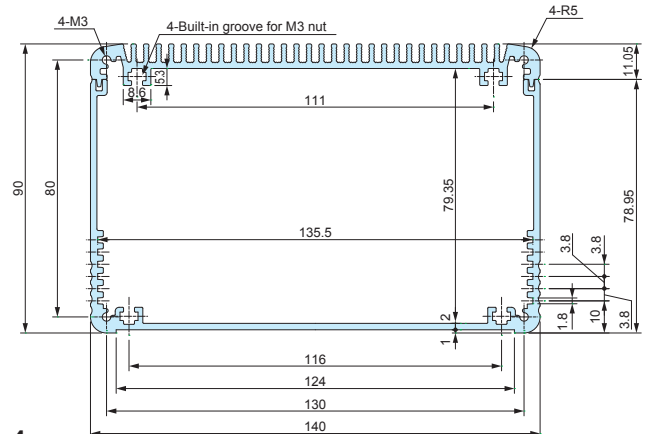

Cross-section view of heat-sink top cover & bottom frame

■ DXF/DWG/PDF drawings available on our website.

EXHS187-44-□

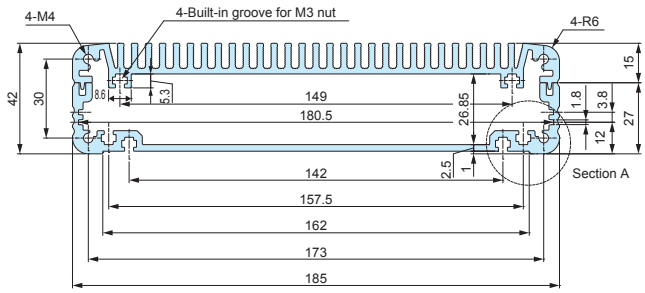

EXHS187-62-□

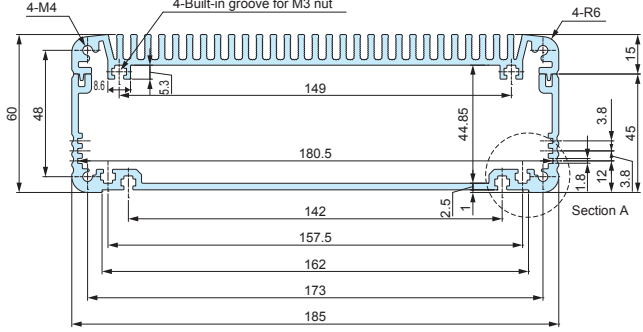

EXHS187-82-□

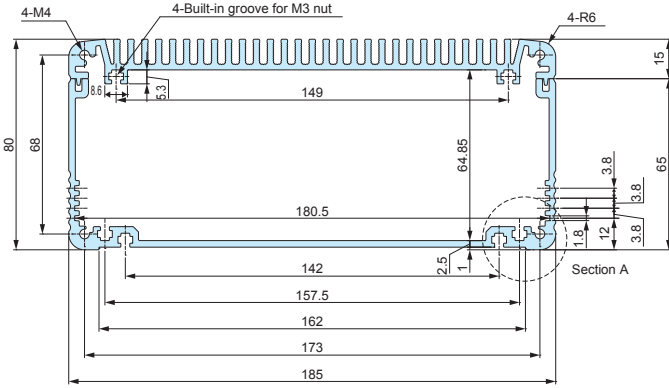

EXHS187-107-□

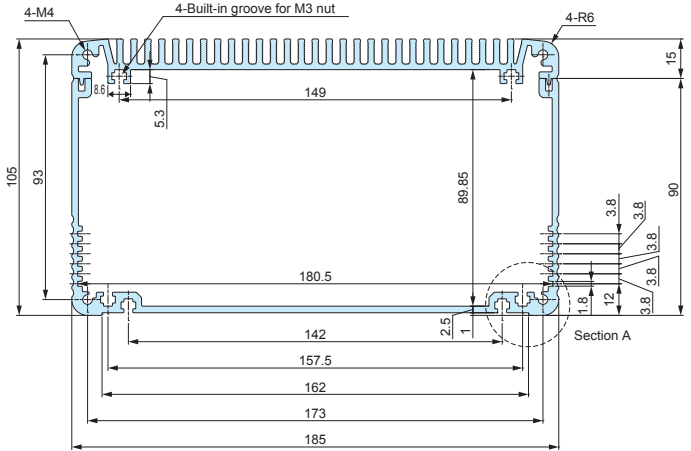

EXHS232-52-□

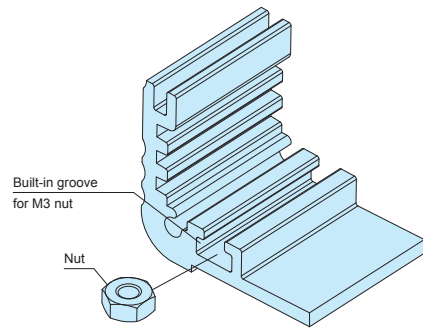
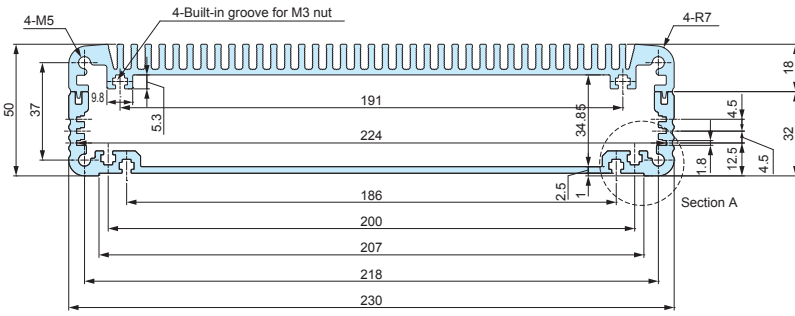

EXHS232-77-□

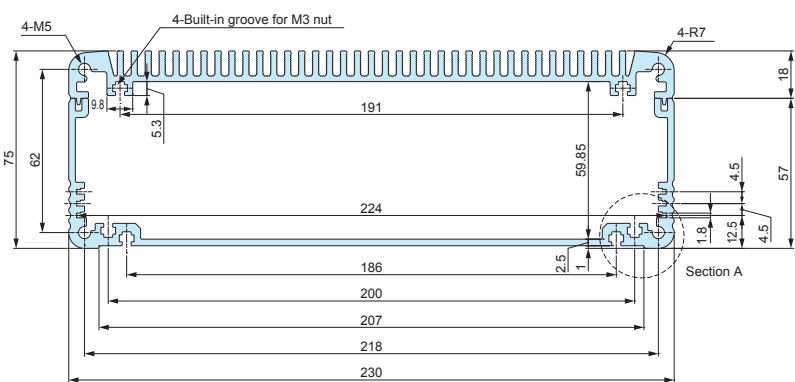

■ Optional M3 nut is available.
 Sliding nut can be used on all EXHS models with width 140mm and larger bottom covers, as well as all heat-sink top covers.
 See page EF-36 • MT-3N for MT-3N optional M3 nut.

※ See page EXHS-6 for detailed dimensions of Section A

Cross-section view of heat-sink top cover & bottom frame

■ DXF/DWG/PDF drawings available on our website.

EXHS232-102-□

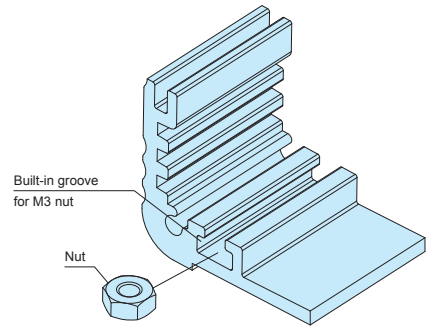
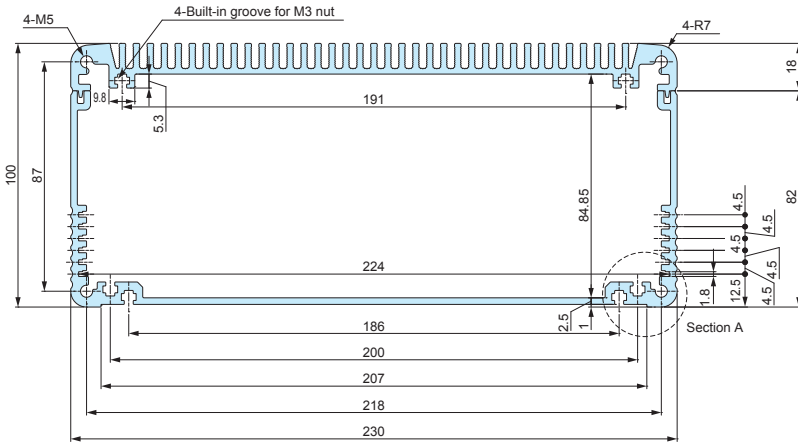

■ Optional M3 nut is available.
Sliding nut can be used on all EXHS models with width 140mm or larger bottom covers, as well as all heat-sink top covers.
See page EF-36 • MT-3N for MT-3N optional M3 nut.

EXHS288-78-□

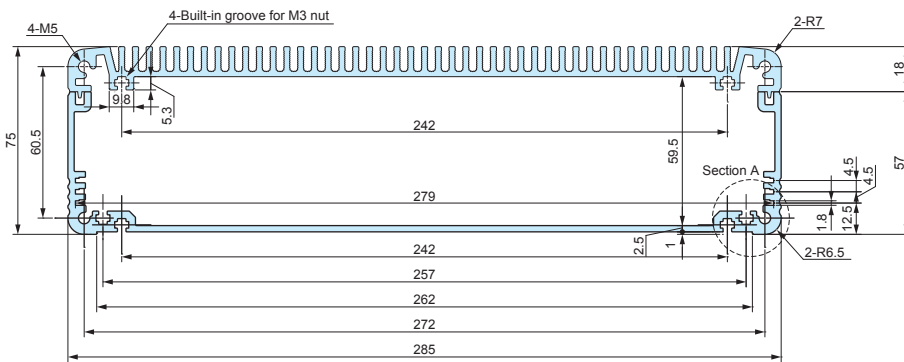

EXHS288-128-□

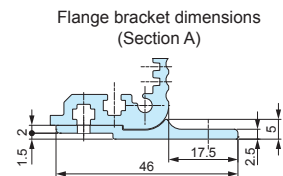
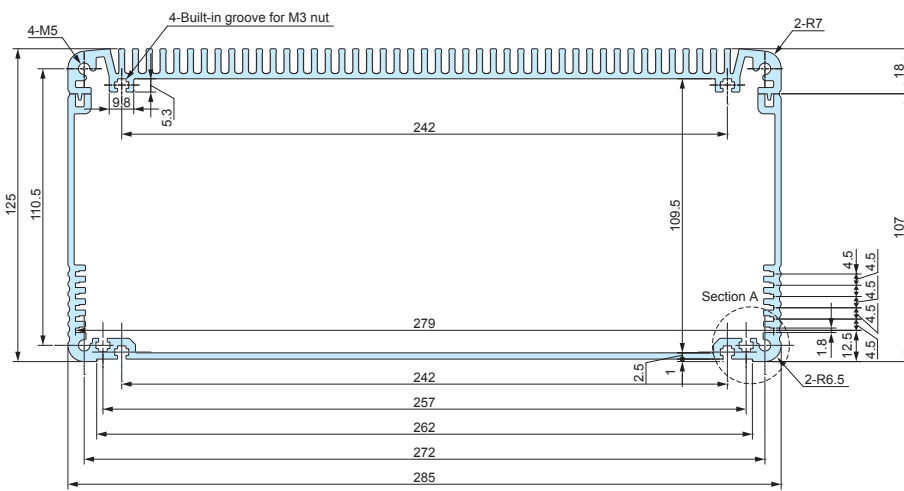

EF-36 series

WALL MOUNTING BRACKET for EXS • EXHS

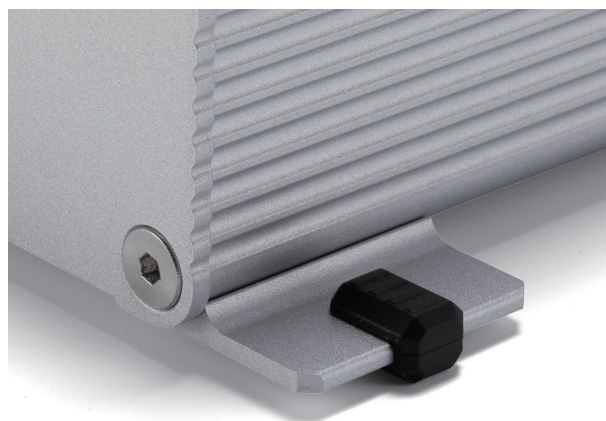
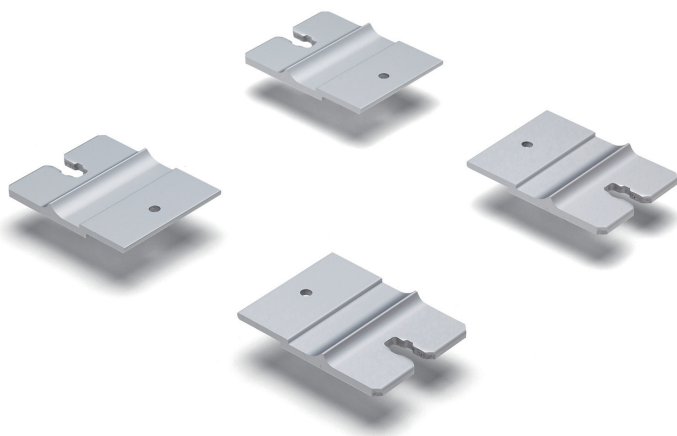

Assembly drawings

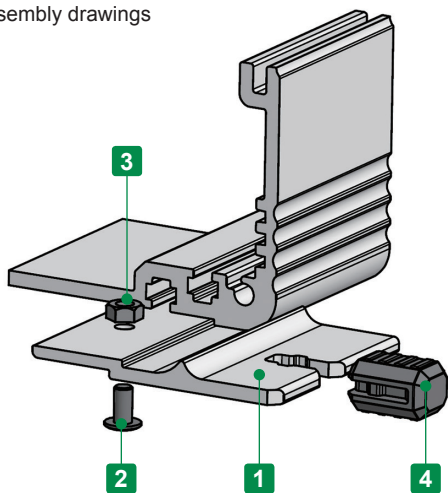

Utilize rubber feet inserts when placing on tables or flat surfaces.

EF-36 dimensions

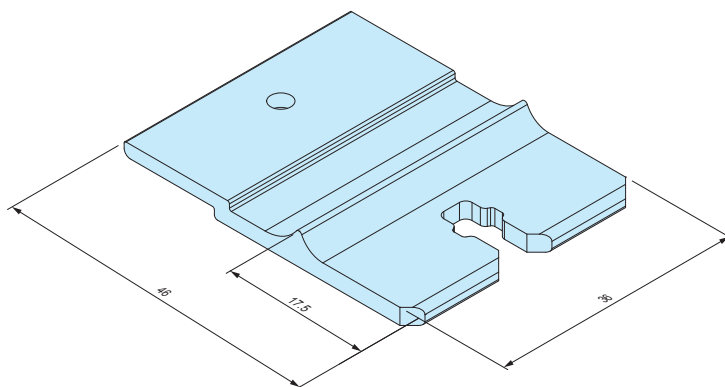

■ DXF/DWG/PDF/STP drawings available on our website.

Components

| No. | Part name | Pcs | Material | Color / Finish |
|-----|------------------------|-----|------------------------------|--|
| 1 | Bracket | 4 | Extruded aluminium A6063S-T5 | Metallic silver / Painted : Black / Anodized |
| 2 | Screw (Slim head M3-6) | 4 | Steel | Black trivalent chromate |
| 3 | Nut (For M3 screw) | 4 | Steel | Black trivalent chromate |
| 4 | Insert rubber feet | 4 | Silicone | Black |

Product no.

| Product no. | |
|-----------------------------|--------------------|
| ● Metallic silver / Painted | ● Black / Anodized |
| EF-36S | EF-36B |

■ Applicable to be used on EXS series with 185mm or larger bottom covers, and EXHS series with 187mm or larger bottom covers.

MT-3N

SLIDING NUT for EXPS • EXPFS • EXWS • EXWFS • EXS • EXHS

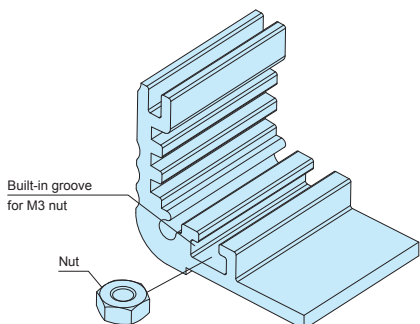

MT-3N dimensions

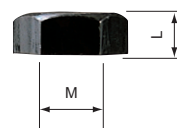

Product no. / Dimensions

| Product no. | M | L | Material | Finish | Pack of |
|-------------|---|-----|----------|--------------------------|---------|
| MT-3N | 3 | 2.4 | Steel | Black trivalent chromate | 50 |

■ Sliding nut can be used on all EXPS • EXPFS • EXWS • EXWFS • EXS models with width 140mm or larger bottom covers and with width 230mm and 285mm top covers, as well as on all EXHS models with width 140mm or larger bottom covers and on all heat-sink top cover sizes.