

# BCAL SERIES

# IP65 PLASTIC BOX

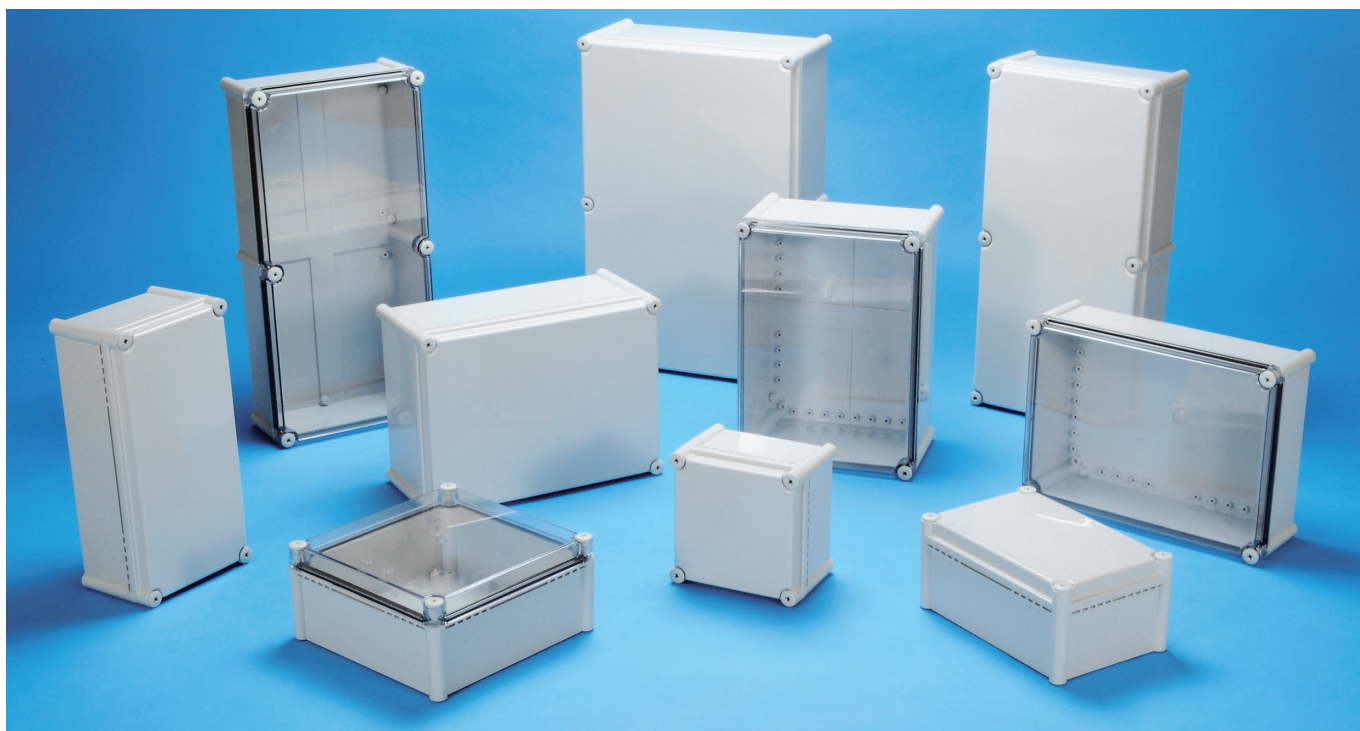

### Technical Data



Protection class: IP65  
 Operating temperature: -10°C ~ +60°C  
 Recommended torque: 1N • m ~ 1.5N • m

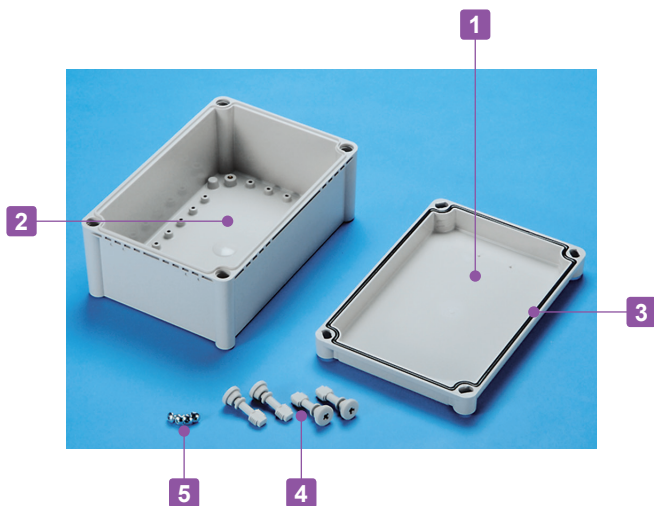

- Large-sized frontal screw fastening type waterproof box.
- 11 different sizes available.
- Applicable for uses in various fields such as FA, control box, network communication, and so on.
- 2 different top cover models (ABS-White gray • Polycarbonate-Transparent) are available.
- Guide markings are available for installation of optional latch/hinge parts.

◎ : Guide markings



### Components

No.	Part name	Pcs	Material	Color / Finish
1	Top cover	1	ABS UL94HB • Polycarbonate (UL94V-0)	White gray • Transparent
2	Body	1	ABS UL94HB	White gray
3	Gasket	1	Polyurethane	Black
4	Cover screw	4 ~ 6	Nylon	White gray • Unfinished
5	Tapping screw (for mounting plate)	4	Steel	Trivalent chromate

**BCAL dimensions**

■ Drawings below are reference examples only.  
DXF/DWG/PDF drawings available on our website.

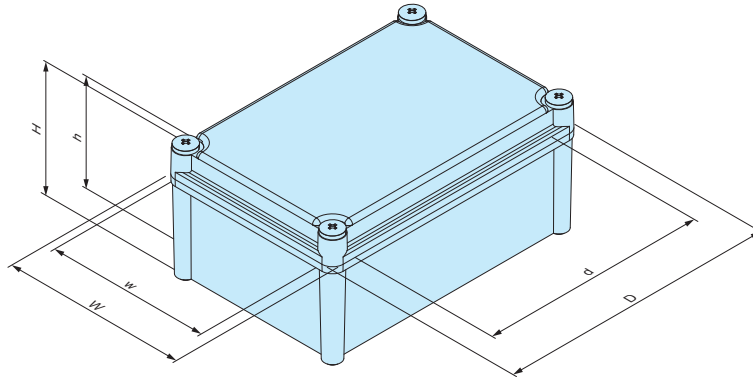

**Product no. / Dimensions**

Product no.		Product no.		Dimensions (External)			Dimensions (Internal)			Weight (g)
G type		T type		W	D	H	w	d	h	
Top cover	Body	Top cover	Body							
● White gray		○ Transparent	● White gray							
BCAL191913G			BCAL191913T	190	190	128	167	140	111.5	722
BCAL192813G			BCAL192813T	190	280	128	166	229	111.5	896
BCAL192818G			BCAL192818T	190	280	178	164	230	162	1,009
BCAL193813G			BCAL193813T	190	380	128	167	329	111	1,143
BCAL193818G			BCAL193818T	190	380	178	165	327.5	162	1,258
BCAL282813G			BCAL282813T	280	280	128	256	229	112	1,148
BCAL283413G			BCAL283413T	280	340	128	255.5	287	111.8	1,441
BCAL283813G			BCAL283813T	280	380	128	256	329	111.5	1,423
BCAL283818G			BCAL283818T	280	380	178	254	324	161.5	1,745
BCAL285613G			BCAL285613T	280	560	128	255	507	112	2,272
BCAL385618G			BCAL385618T	380	560	178	354	505	159.7	2,948

**Accessories (Optional parts)**

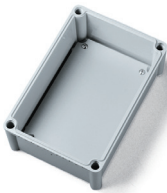

Mounting plate BMP series  
See page BCAL-3

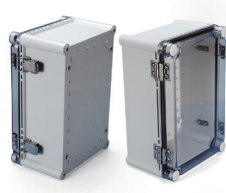

Latch • Hinge BCL65 • BCH65  
See page BCAS • BCAL-ACC-1

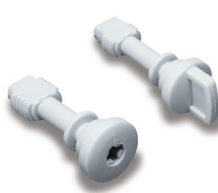

Spare Cover screw CB28 series  
See page BCAS • BCAL-ACC-3



Mounting bracket CK-26P  
See page BCAS • BCAL-ACC-2



Cable gland  
See cable gland pages

**APPLICATION EXAMPLE**

CONTROL BOX



INCLINOMETER for Bridge Construction

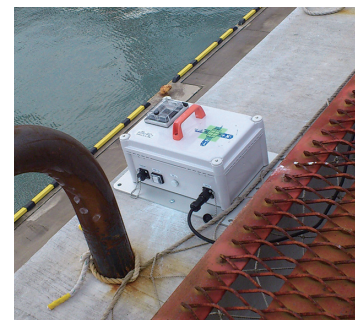

**BMP-Z SERIES**

**STEEL MOUNTING PLATE**

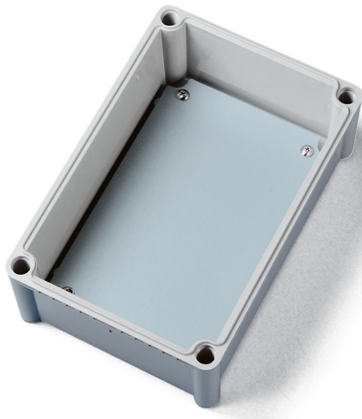

DXF/DWG/PDF drawings available on our website.

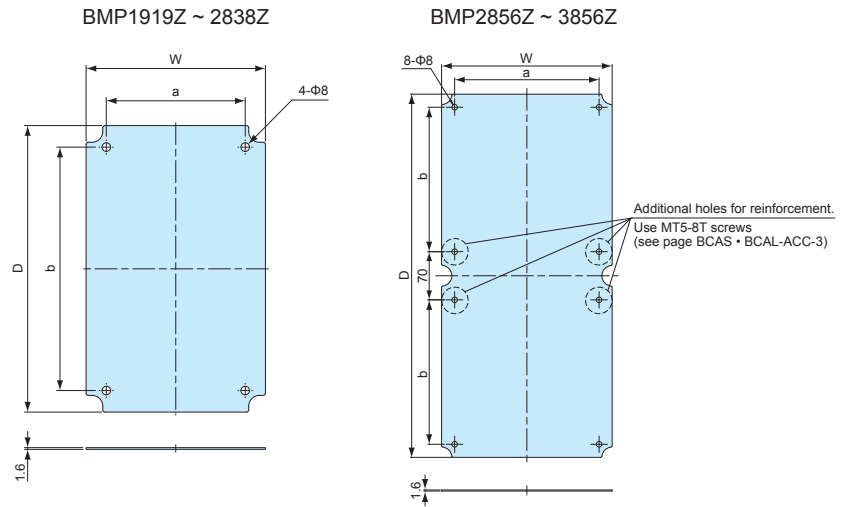

- Strong but easily customizable.
- Material/Finish : Steel t=1.6mm / Zinc coated

**Product no. / Dimensions**

Product no.	W	D	a	b	Suitable box	Weight (g)
BMP1919Z	159	159	120	120	BCAL191913	303
BMP1928Z	157	247	120	210	BCAL192813, 192818	462.5
BMP1938Z	159	347	120	310	BCAL193813, 193818	676.5
BMP2828Z	246	246	210	210	BCAL282813	727.5
BMP2834Z	246	306	210	270	BCAL283413	920
BMP2838Z	246	346	210	310	BCAL283813, 283818	1,018
BMP2856Z	248	528	210	210	BCAL285613	1,571
BMP3856Z	348	528	310	210	BCAL385618	2,210

**BMP-P SERIES**

**PLASTIC MOUNTING PLATE**

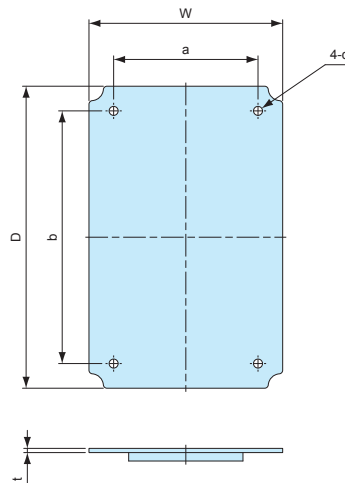
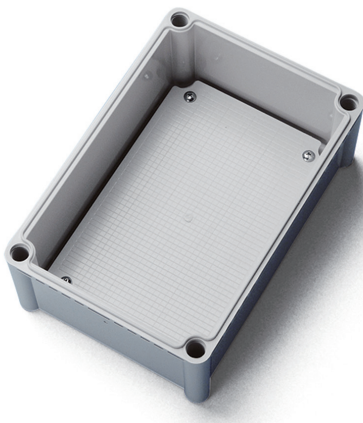

- Not available for BCAL283413, 285613, and 385618 models.
- Material/Color : ABS / White gray

**Product no. / Dimensions**

Product no.	W	D	a	b	c (Φ)	t	Suitable box	Weight (g)
BMP1919P	159	159	120	120	Φ8	4	BCAL191913	104
BMP1928P	158.5	248	120	210	Φ8	3.5	BCAL192813, 192818	162
BMP1938P	159	348	120	310	Φ8	4.5	BCAL193813, 193818	236
BMP2828P	248.5	248.5	210	210	Φ8	4	BCAL282813	237
BMP2838P	248	347.5	209	309.5	Φ8	4	BCAL283813, 283818	368

**BCH SERIES**

**HINGE for BCAS • BCAL**

■ Refer to ☉ guide markings on BCAS • BCAL box when installing.

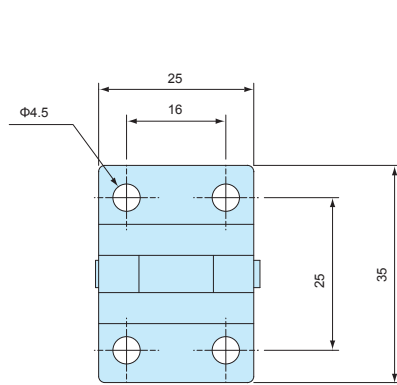

BCH55

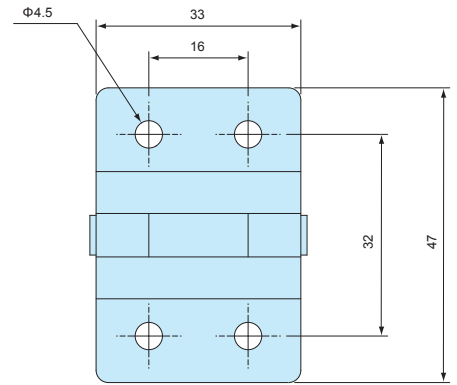

BCH65

**Components**

Part name	Pcs	Material	Color / Finish
Hinge	1	Stainless steel SUS304	Unfinished
Bracket	2	Stainless steel SUS304	Unfinished
Gasket	2	EPDM	Black

**Product no. / Suitable box**

Product no.	Suitable box	Included screw
BCH55	BCAS series Not available for BCAS050604, 050605, 060905, 071005, 080806, 081104, 101807, 102007, 102307, 152004, and 161607 models.	Truss head M4-10
BCH65	BCAL series	Truss head M4-10

**BCL SERIES**

**LATCH for BCAS • BCAL**

■ Refer to ☉ guide markings on BCAS • BCAL box when installing.

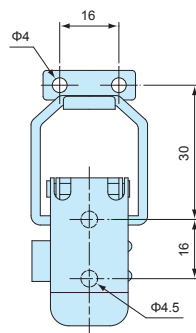

BCL55

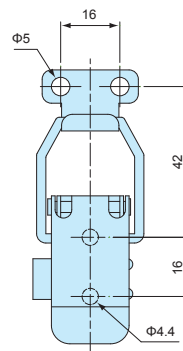

BCL65

**Components**

Part name	Pcs	Material	Color / Finish
Latch	1	Stainless steel SUS304	Unfinished
Hook	1	Stainless steel SUS304	Unfinished
Bracket	2	Stainless steel SUS304	Unfinished
Gasket	2	EPDM	Black

**Product no. / Suitable box**

Product no.	Suitable box	Included screw
BCL55	BCAS series Not available for BCAS050604, 050605, 060905, 071005, 080806, 081104, 101807, 102007, 102307, 152004, and 161607 models.	Truss head M4-10
BCL65	BCAL series	Truss head M4-10

**BCM SERIES**

**BLIND PLUG for BCAS • BCAL**



- Blind plug for BCAS • BCAL when installing hinges and latches.  
Not usable when using cover screws.

**Components**

Part name	Material	Color
Blind plug	ABS	White gray

**Product no. / Suitable box**

Product no.	Suitable box	Pack of
BCM-1	BCAS series (Not available for BCAS050604, 050605 models)	1
BCM-2	BCAL series	1

**CK SERIES**

**STAINLESS STEEL MOUNT BRACKET**



CK-34Z dimensions

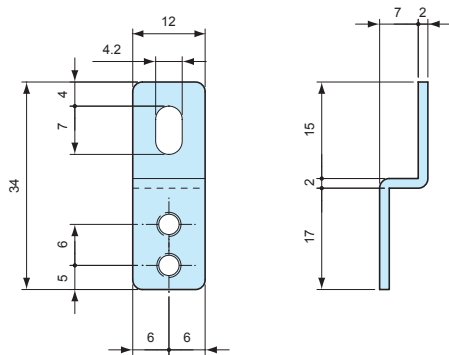

CK-35P dimensions

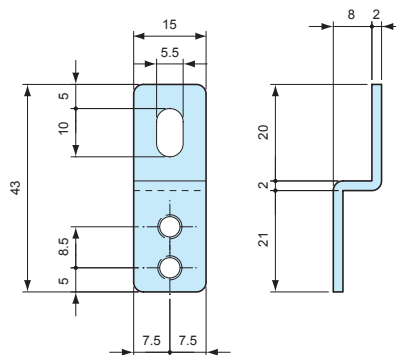

CK-26P dimensions

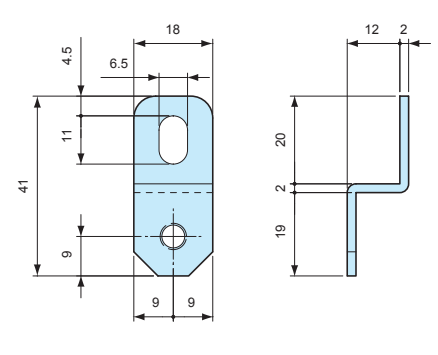

- CK-34Z model requires the use of MT4-10 screw.

**Product no. / Suitable box**

Product no.	Material	Finish	Suitable box	Included screw	Pack of
CK-34Z	Stainless steel SUS304	Barrel finish	BCAS series (Not applicable for BCAS050604, 050605 models)	-	4
CK-35P	Stainless steel SUS304	Barrel finish	BCAS050604G, BCAS050605G	Pan head tapping M4-10	4
CK-26P	Stainless steel SUS304	Barrel finish	BCAL series	Pan head M5-10	4

**MT4-10**

**MOUNTING SCREW**

- Use together with CK-34Z.

**Product no. / Feature**

Product no.	Material	Finish	Pack of
MT4-10 (Pan head M4-10)	Stainless steel	Unfinished	4

**MT SERIES**

**PCB MOUNTING SCREW**



■ Mounting screw for the bosses without insert-nut.

**Product no. / Feature**

Product no.	Material	Finish	Pack of
MT4-8T (Binding head tapping M4-8)	Steel	Trivalent chromate	20
MT5-8T (Binding head tapping M5-8)	Steel	Trivalent chromate	20

**Suitable box chart**

Product no.	Suitable box	Tightening torque
MT4-8T	BCAS071005, 081104, 081107, 081108, 081110, 081307, 081308, 081807, 081808, 082507, 082508, 101007, 101010, 101807, 102007, 102307, 121207, 121210, 141709, 142309, 151507, 151510, 152004, 152007, 152010, 152013, 152016, 152510, 152513, 161607, 202010, 202013, 202016, 202019, and 212310 models.	0.7N • m
MT5-8T	BCAL series	1.4N • m

**CB SERIES**

**SPARE COVER SCREW for BCAS**



**Product no. / Feature / Suitable box**

Product no.	Material	Color	Pack of
CB20	Fiberglass • Nylon	White gray	1
CB35	Fiberglass • Nylon	White gray	1
CB50	Fiberglass • Nylon	White gray	1

Product no.	Suitable box
CB20	BCAS060905, 071005, 080806, 081104, 081107, 081108, 081307, 081807, 082507, 101007, 101010, 101807, 102007, 102307, 121207, 121210, 141709, 142309, 151507, 151510, 152004, 152007, 152010, 152013, 152510, 161607, 202010, 202013, 202016, and 212310 models TMB-15PS, 20P, 20PL
CB35	BCAS081110, 081308, 081808, and 082508 models
CB50	BCAS152016, 152513, and 202019 models

**CB SERIES**

**SPARE COVER SCREW for BCAL**

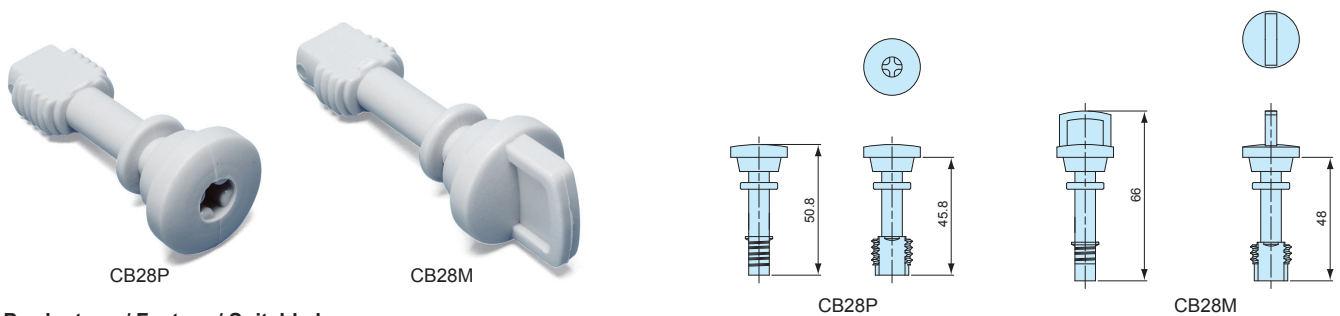

**Product no. / Feature / Suitable box**

Product no.	Material	Color	Suitable box	Pack of
CB28P	Fiberglass • Nylon	White gray	BCAL series	1
CB28M	Fiberglass • Nylon	White gray	BCAL series	1

SSK SERIES

POLE MOUNTING BRACKET



- Stainless steel pole mounting bracket for SPCM • SPCP and BCAL • BCAS series.
- Easy pole mount with the use of SSK-B mounting screw and PKB mounting belt.
- DXF/DWG/PDF drawings available on our website.
- SSK-P models includes plastic mounting brackets.



PKB series

SSK dimensions

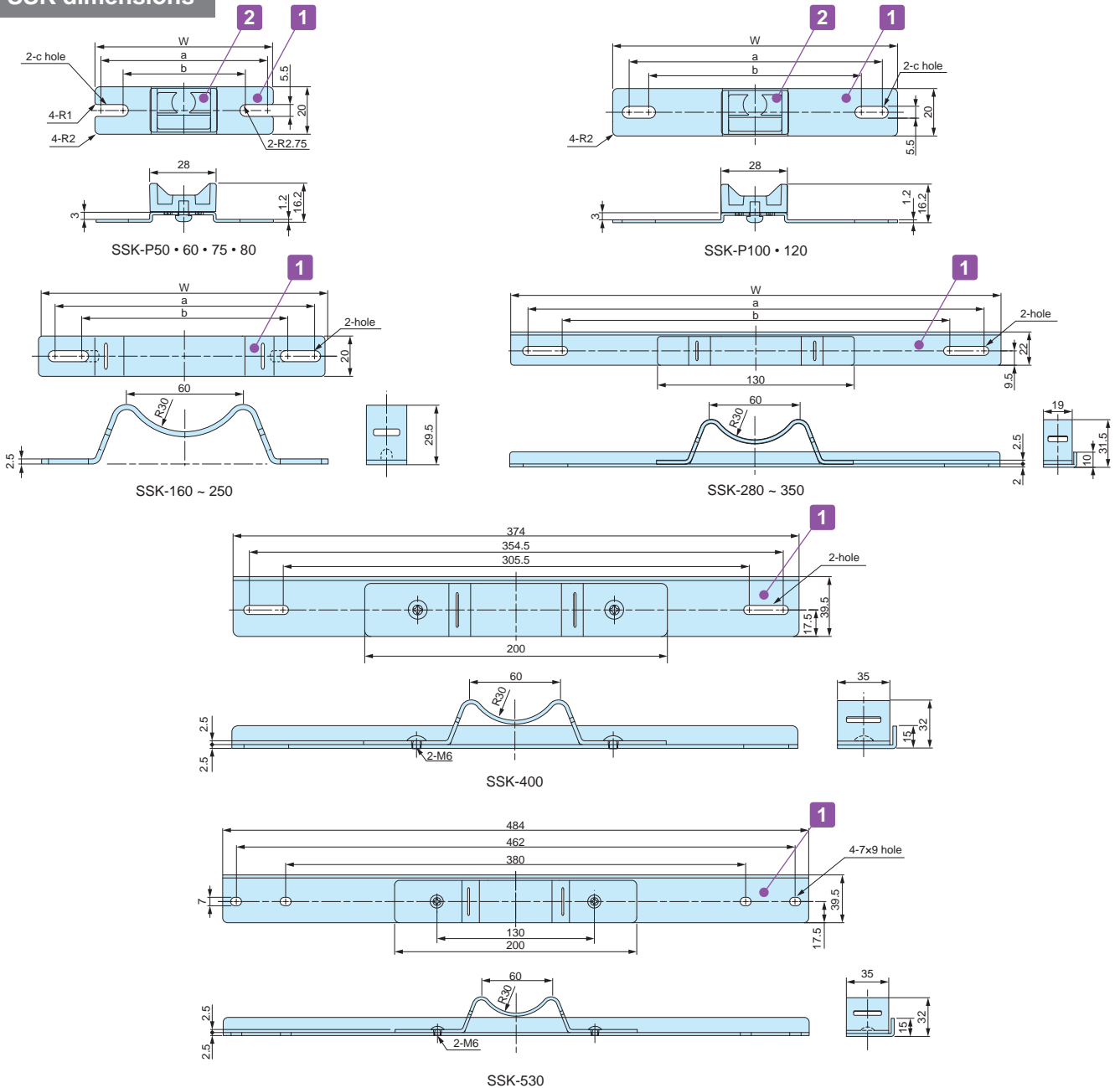

SSK-1

Components

No.	Part name	Pcs	Material	Color / Finish
1	Bracket	2	Stainless steel SUS304	Barrel finish
2	Plastic bracket (SSK-P models only)	2	ASA UL94HB	White gray

■ Screws included with SSK brackets are for BCAP • BCAR • BCPK • BCPR series use only. For other series, please utilize SSK-B screw set.

Product no. / Dimensions

Product no.	W	a	b	c	Suitable mounting belt	Pack of
SSK-P50	50	44.5	37.5	5.5x 9	PKB-10PM, 10P PKB-10S	2
SSK-P60	60	54.5	47.5	5.5x 9	PKB-10PM, 10P PKB-10S	2
SSK-P75	75	69.5	55.5	5.5x12.5	PKB-10PM, 10P PKB-10S	2
SSK-P80	80	74.5	64.5	5.5x10.5	PKB-10PM, 10P PKB-10S	2
SSK-P100	100	88.1	76.5	5.5x11.3	PKB-10PM, 10P PKB-10S	2
SSK-P120	120	106.5	88.5	5.5x14.5	PKB-10PM, 10P PKB-10S	2
SSK-160	142	129.5	106.5	-	PKB-10PM, 10P PKB-10S	2
SSK-170	152	142.3	101	-	PKB-10PM, 10P PKB-10S	2
SSK-200	174	161.5	112.5	-	PKB-10PM, 10P PKB-10S	2
SSK-210	192	180.5	131.5	-	PKB-10PM, 10P PKB-10S	2
SSK-250	230	215.5	166.5	-	PKB-10PM, 10P PKB-10S	2
SSK-280	260	244.5	195.5	-	PKB-10PM, 10P PKB-10S	2
SSK-300	280	264.5	215.5	-	PKB-10PM, 10P PKB-10S	2
SSK-350	324	302.5	253.5	-	PKB-10PM, 10P PKB-10S	2
SSK-400	374	354.5	305.5	-	PKB-20S	2
SSK-530	484	462	380	7x9	PKB-20S	2

SSK-B SERIES

MOUNTING SCREW SET for SSK



- Mounting screw set for use with SSK pole mounting bracket.
- See chart on page SSK-3 for appropriate bracket/screw/box combination.
- Material / Finish : Stainless steel / Unfinished.

Product no. / Dimensions

Product no.	Included screws	Suitable box	Pcs
SSK-B4-15N	M4-15 Pan head with nut	BCAS060905 ~ 212310	4
SSK-B4-25N	M4-25 Pan head with nut	SPCP • SPCM series	4
SSK-B5-10	M5-10 Pan head	BCAL series	4

■ Installation Example

BCAS050604, 050605

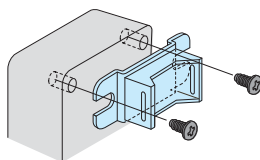

Use screws included with SSK-P

M4 / M5 Pan head with nut fastening

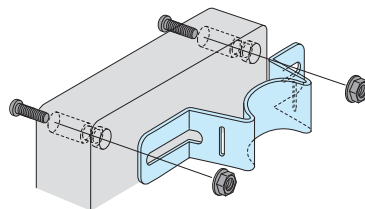

SSK-B4-15N      SSK-B4-25N

Pan head screw into insert nut

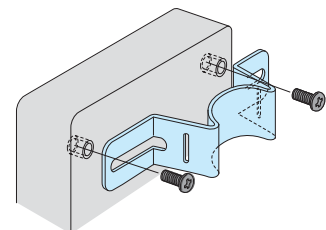

SSK-B5-10



POLE MOUNTING BRACKET / SCREW SET MATCHING CHART

SPCM • SPCP series

	Box Product no.	SSK Product no.		Screw set Product no.
		Vertical mount	Horizontal mount	
SPCP SPCM	081304, 081305 081306, 081308 081310, 081313	SSK-P75	SSK-160	SSK-B4-25N
	101004, 101006	SSK-P100	SSK-P100	SSK-B4-25N
	131304, 131305 131306, 131308 131310, 131313	SSK-160	SSK-160	SSK-B4-25N
	131804, 131805 131806, 131808 131810, 131813, 131815	SSK-160	SSK-200	SSK-B4-25N
	181808, 181810 181813, 181815	SSK-200	SSK-200	SSK-B4-25N
	182508, 182510, 182515	SSK-200	SSK-280	SSK-B4-25N

BCAL series

	Box Product no.	SSK Product no.		Screw set Product no.
		Vertical mount	Horizontal mount	
BCAL	191913 ※	SSK-P120	SSK-200	SSK-B5-10
	192813, 192818	SSK-200	SSK-250	SSK-B5-10
	193813, 193818	SSK-200	SSK-350	SSK-B5-10
	282813	SSK-250	SSK-280	SSK-B5-10
	283413	SSK-280	SSK-280	SSK-B5-10
	283813, 283818	SSK-280	SSK-350	SSK-B5-10
	285613	SSK-280	SSK-530	SSK-B5-10
	385618	SSK-400	SSK-530	SSK-B5-10

※Use screws included with SSK bracket for vertical mount

BCAS series

	Box Product no.	SSK Product no.		Screw set Product no.
		Vertical mount	Horizontal mount	
BCAS	050604, 050605	SSK-P50	SSK-P60	Use screws included with SSK bracket
	060905	SSK-P60	SSK-P100	SSK-B4-15N
	071005 ※	SSK-P75	SSK-P100	SSK-B4-15N
	080806	SSK-P75	SSK-P75	SSK-B4-15N
	081104, 081107 081108, 081110	SSK-P75	SSK-P120	SSK-B4-15N
	081307, 081308	SSK-P75	SSK-160	SSK-B4-15N
	081807, 081808	SSK-P75	SSK-210	SSK-B4-15N
	082507, 082508	SSK-P75	SSK-280	SSK-B4-15N
	101007, 101010	SSK-P100	SSK-P100	SSK-B4-15N
	101807	SSK-P100	SSK-210	SSK-B4-15N
	102007	SSK-P100	SSK-250	SSK-B4-15N
	102307	SSK-P100	SSK-250	SSK-B4-15N
	121207, 121210	SSK-P120	SSK-200	SSK-B4-15N
	141709	SSK-160	SSK-200	SSK-B4-15N
	142309	SSK-160	SSK-250	SSK-B4-15N
	151507, 151510	SSK-170	SSK-170	SSK-B4-15N
	152004, 152007 152020, 152013, 152016	SSK-170	SSK-250	SSK-B4-15N
	152510, 152513	SSK-170	SSK-280	SSK-B4-15N
	161607	SSK-170	SSK-170	SSK-B4-15N
	202010, 202013 202016, 202019	SSK-250	SSK-250	SSK-B4-15N
	212310	SSK-250	SSK-250	SSK-B4-15N

※Use screws included with SSK bracket for vertical mount

- For installation of SR series outdoor roof on SPCM • SPCP series SR series (For SPCM • SPCP - see page SPCM • SPCM-ACC-2)

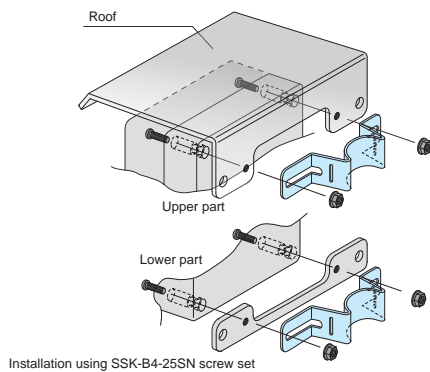

- Select SSK bracket depending on mounting type (Vertical or Horizontal).

Vertical mount

(Longer vertical side)

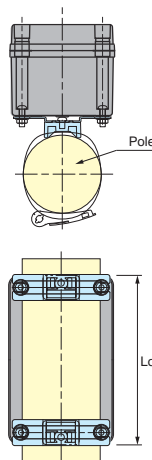

Horizontal mount

(Longer horizontal side)

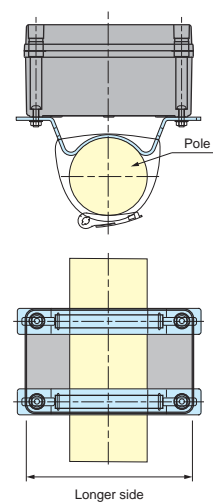

WPMB-M4-3 SERIES

POLE MOUNTING BRACKET



- Pole mount bracket made from weather resistant ASA material.
- Suitable for both for vertical and horizontal mounting.
- Hole milling is required for bracket installation.
- IPX7 protection can be maintained through the use of sealing washers.
- Pole mount is possible with the use of PKB series mounting belt.

Components

No.	Part name	Pcs	Material	Color / Finish
1	Bracket	1	ASA UL94HB	White gray • Dark gray
2	Sealing washer	2	NBR, SPCC	Black
3	Screw (M4-10 Pan head)	2	Stainless steel	Unfinished
4	Hexagonal nut (M4 x 3 types)	2	Stainless steel	Unfinished

Product no. / Dimensions

Product no.		Material thickness	Tightening torque	Tensile strength	Weight (g)
• White gray	• Dark gray				
WPMB-M4-3G	WPMB-M4-3D	Up to t = 4.0mm	0.45N • m	5 kg	26.5

■ Listed tightening torque values are for reference only. Actual required torque may differ.

■ DXF/DWG/PDF drawings available on our website.

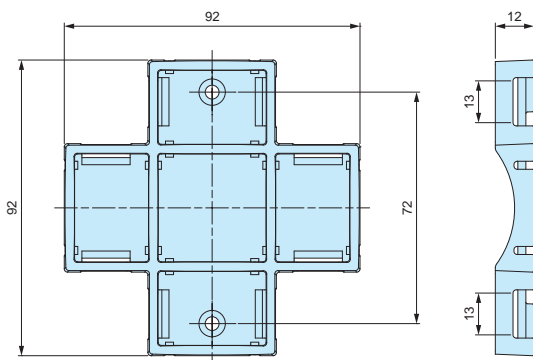

Installation example

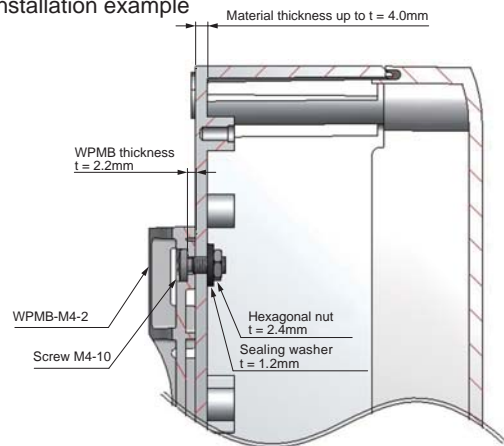

PKB SERIES

POLE MOUNTING BELT



PKB-10PM, 10P



PKB-10S, 20S

- New shorter belt type PKB-10PM is available for  $\Phi 25$  to  $\Phi 60$ mm poles. Other belt types are for  $\Phi 60$  to  $\Phi 400$ mm poles.
- Designed for one time use only (not reusable).
- Strong stainless steel clamping type and easy installation plastic type are available.
- Use SSK • WPMB mounting bracket for installation onto a pole.

■ Drawings below are reference examples only. DXF/DWG/PDF drawings available on our website.

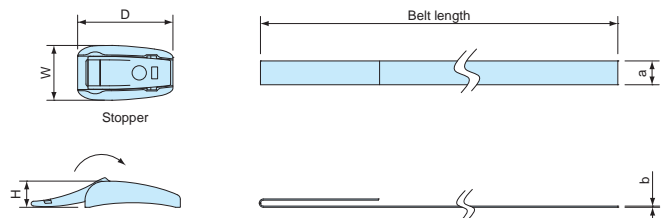

Components

Part name	Pcs	Material	Color / Finish
Stopper	2	POM • Stainless steel SUS304	Black • Barrel finish
Belt	2	PET • Stainless steel SUS430	Gray • Bright Annealed finish

Product no. / Dimensions

Product no.	W	D	H	a	b	Belt material	Belt length	Tensile strength (horizontal)	Weight (g)	Pack of
<b>NEW</b> PKB-10PM	24	23	11	10	0.5	PET	500mm	0.8kN	14	2
PKB-10P	23	40	11	10	0.5	PET	1,500mm	1.3kN	31.8	2
PKB-10S	(16.5)	(49.5)	12	10	0.3	Stainless steel	1,500mm	1.4kN	101.6	2
PKB-20S	(27.4)	(49.5)	12	20	0.3	Stainless steel	1,500mm	2.9kN	182.2	2

# WGMB-2SW

# POLE MOUNTING BRACKET

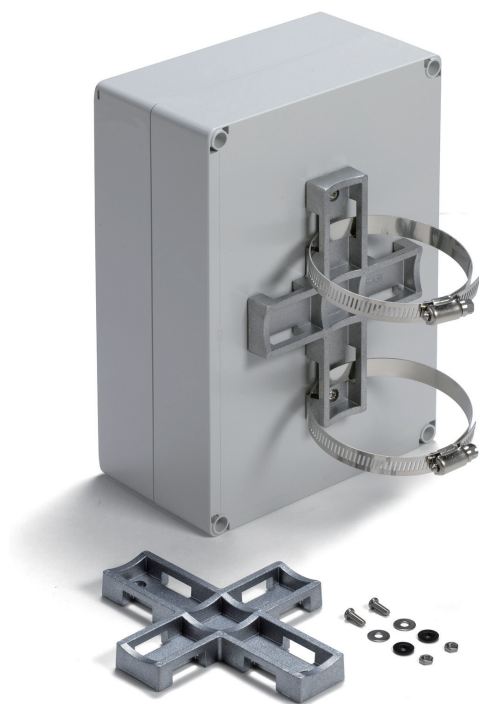

- Pole mount bracket made from robust diecast aluminium.
- Bracket can be mounted on both vertically, and horizontally.
- Sealing washers enables the installation to have a protection class equivalent to IPX7, X5.
- Hole milling on enclosures is required when installing mounting bracket.
- Pole mount is possible with the use of SNB or PKB series mounting belt. (See page 323 ~ 324)
- Installation can be done on a variety of enclosures made from plastic, diecast aluminium or stainless steel.

## WGMB-2SW dimensions

■ DXF/DWG/PDF drawings available on our website.

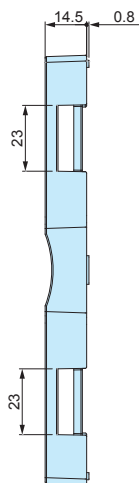
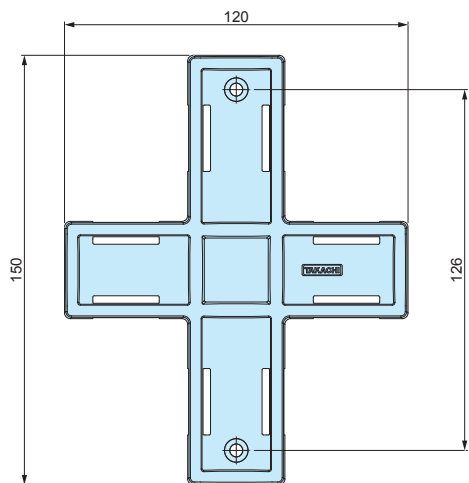

## Installation example

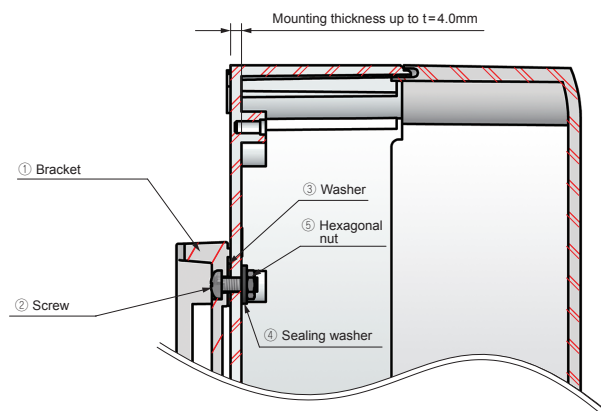

## Components

No.	Part name	Pcs	Material	Color / Finish
1	Bracket	1	Diecast aluminium ADC12	Natural / Shot blast
2	Screw (Pan head M4-10)	2	Stainless steel	Unfinished
3	Washer	2	Stainless steel	Unfinished
4	Sealing washer	2	NBR, SPCC	Black
5	Hexagonal nut (M4-JIS Type3)	2	Stainless steel	Unfinished

## Product no. / Details

Product no.	Mounting thickness	Recommended torque	Weight (g)
WGMB-2SW	Up to t=4.0mm	0.45N · m ~ 0.5N · m	130

■ Recommended torque listed is for reference only; actual may differ. Assemble after testing torque.

SNB series

STAINLESS STEEL POLE MOUNTING STRAP



SNB dimensions

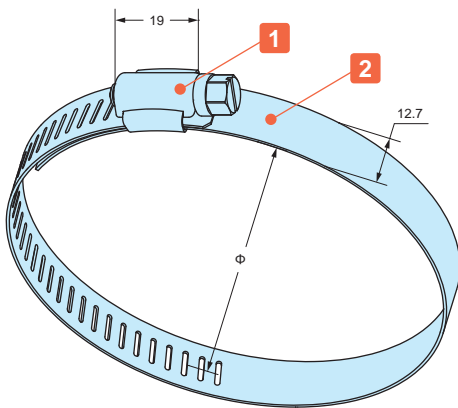

- Corrosion resistant stainless steel (SUS304) belt clamp.
- It can be installed securely by tightening the screw.
- 8 mm nut driver (box driver) is recommended for tightening. Minus screw driver can also be used.

Components

No.	Part name	Pcs	Material	Finish
1	Bracket	1	Stainless steel SUS304	Polished
2	Strap	1	Stainless steel SUS304	Polished

Product no. / Dimensions

Product no.	Applicable diameter (Φ)	Strap width	Strap thickness	Recommended torque N · m	Weight (g)	Pack of
SNB 52- 76	52 ~ 76	12.7	0.6	0.7 ~ 1.0	27.5	1
SNB 72- 95	72 ~ 95	12.7	0.6	0.7 ~ 1.0	30	1
SNB 91-114	91 ~ 114	12.7	0.6	0.7 ~ 1.0	34.5	1
SNB105-127	105 ~ 127	12.7	0.6	0.7 ~ 1.0	37.5	1
SNB117-140	117 ~ 140	12.7	0.6	0.7 ~ 1.0	39.5	1
SNB130-153	130 ~ 153	12.7	0.6	0.7 ~ 1.0	41.5	1
SNB142-165	142 ~ 165	12.7	0.6	0.7 ~ 1.0	43.5	1
SNB155-178	155 ~ 178	12.7	0.6	0.7 ~ 1.0	46.5	1
SNB168-191	168 ~ 191	12.7	0.6	0.7 ~ 1.0	49	1
SNB181-204	181 ~ 204	12.7	0.6	0.7 ~ 1.0	51	1
SNB194-217	194 ~ 217	12.7	0.6	0.7 ~ 1.0	52.5	1
SNB207-230	207 ~ 230	12.7	0.6	0.7 ~ 1.0	57	1
SNB220-243	220 ~ 243	12.7	0.6	0.7 ~ 1.0	59.5	1
SNB233-256	233 ~ 256	12.7	0.6	0.7 ~ 1.0	62.5	1
SNB246-269	246 ~ 269	12.7	0.6	0.7 ~ 1.0	64	1
SNB259-282	259 ~ 282	12.7	0.6	0.7 ~ 1.0	67.5	1
SNB272-295	272 ~ 295	12.7	0.6	0.7 ~ 1.0	70	1
SNB285-308	285 ~ 308	12.7	0.6	0.7 ~ 1.0	71	1

■ Recommended torque listed is for reference only; actual may differ. Assemble after testing torque.

SNB Strap required

Suitable series	Suitable models						Required
SSK series	SSK-S1	SSK-160	SSK-170	SSK-200	SSK-210	SSK-250	2
	SSK-280	SSK-300	SSK-350	SSK-400	SSK-530		
WGMB series	WGMB-1W						1

PKB series

POLE MOUNTING BELT



PKB-10PM, 10P



PKB-10S, 20S

- Pole mounting belt for attachment of enclosures with suitable pole mount brackets or construction onto poles.
- Designed for one time use only (not reusable).
- Strong stainless steel clamping type and easy installation plastic type are available.

PKB dimensions

■ DXF/DWG/PDF drawings available on our website.

PKB-10PM, 10P

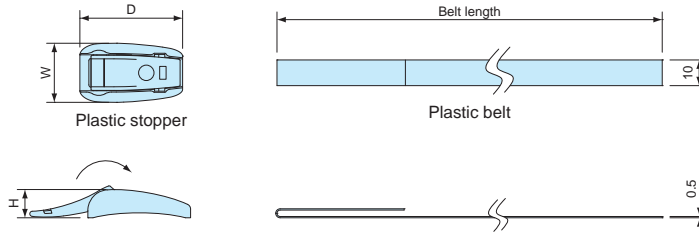

PKB-10S

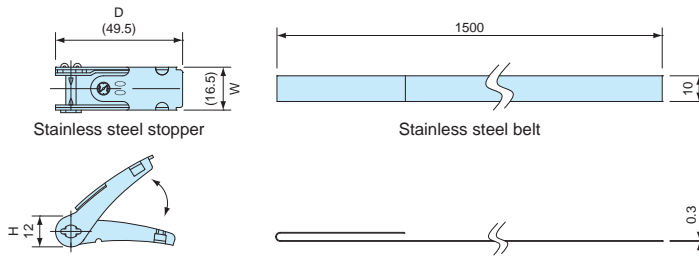

PKB-20S

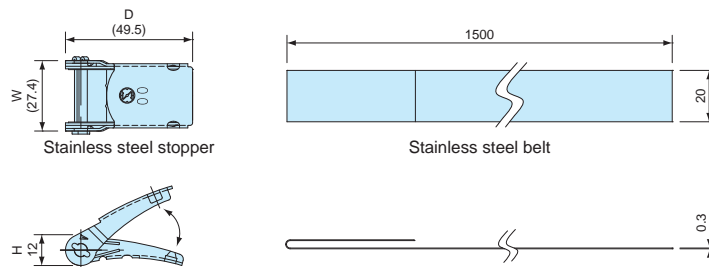

Components

No.	Part name	Material	Color / Finish
1	Stopper	Stainless steel SUS304 • POM	Barrel finish • Black
2	Belt	Stainless steel SUS430 • PET	Bright annealed finish • Gray

Product no. / Dimensions

Product no.	W	D	H	Belt length	Belt material	Tensile strength (horizontal)	Weight (g)	Pack of
PKB-10PM	24	23	11	500 mm	PET	0.8kN	14	2
PKB-10PM	23	40	11	1,500 mm	PET	1.3kN	31.8	2
PKB-10S	16.5	49.5	12	1,500 mm	Stainless steel SUS304	1.4kN	101.6	2
PKB-20S	27.4	49.5	12	1,500 mm	Stainless steel SUS430	2.9kN	182.2	2

FDR SERIES

DIN-RAIL

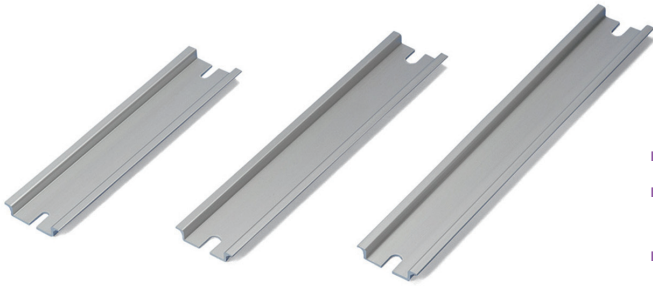

- DIN rail for installation of terminals, relays or switches inside enclosures.
- Available in different models and lengths to fit a wide variety of mounting boss pitch.
- FDR-1000 is available if customized length is required.

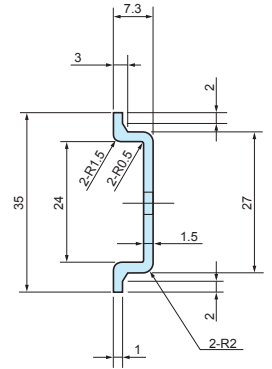
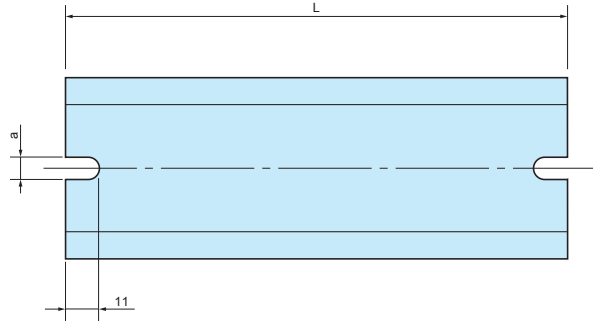
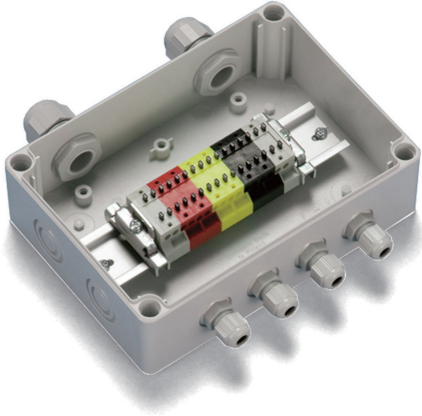

Feature

Material	Finish
Extruded Aluminium A6063S-T5	Silver anodized

Product no. / Dimensions

Product no.	L	a	Matching boss pitch
FDR- 50	50	4.2	32 ~ 42
57	57	4.2	39 ~ 49
66	66	4.2	48 ~ 58
77	77	4.2	59 ~ 69
80	80	4.2	62 ~ 72
87	87	4.2	69 ~ 79
92	92	4.2	74 ~ 84
100	100	4.2	82 ~ 92
106	106	4.2	88 ~ 98
110	110	4.2	92 ~ 102
120	120	4.2	102 ~ 112
128	128	4.2	110 ~ 120
137	137	4.2	119 ~ 129
142	142	4.2	124 ~ 134
146	146	4.2	128 ~ 138
150	150	4.2	132 ~ 142
168	168	4.2	150 ~ 160
170	170	4.2	152 ~ 162
186	186	4.2	168 ~ 178
202	202	4.2	184 ~ 194
205	205	4.2	187 ~ 197
223	223	4.2	205 ~ 215
226	226	4.2	208 ~ 218
235	235	4.2	217 ~ 227
242	242	4.2	224 ~ 234
249	249	4.2	231 ~ 241
283	283	4.2	265 ~ 275
300	300	4.2	282 ~ 292
350	350	4.2	332 ~ 342
450	450	4.2	432 ~ 442
550	550	4.2	532 ~ 542

Product no.	L	a	Matching boss pitch
FDR-B102	102	6.5	86 ~ 92
<b>NEW</b> B124	124	6.5	108 ~ 114
B142	142	6.5	126 ~ 132
B160	160	6.5	144 ~ 150
B165	165	6.5	149 ~ 155
B176	176	6.5	160 ~ 166
B183	183	6.5	167 ~ 173
B223	223	6.5	207 ~ 213
B260	260	6.5	244 ~ 250
B283	283	6.5	267 ~ 273
B303	303	6.5	287 ~ 293
B338	338	6.5	322 ~ 328
B360	360	6.5	344 ~ 350
B376	376	6.5	360 ~ 366
B383	383	6.5	367 ~ 373
B463	463	6.5	447 ~ 453
B560	560	6.5	544 ~ 550
B623	623	6.5	607 ~ 613
FDR-1000	1000	—	—

■ FDR-1000 does not have mounting holes.

Matching DIN-Rail Chart

BC□□ series

Product no.	Matching DIN-Rail
091207	FDR - 80
091208	80
101507	110
101508	110
112107	170
112110	170
112607	223
112610	223
BCAP	
BCPC	
BCPK	
BCAR	
BCPR	
131508	120
131808	150
131810	150
151509	120
151512	120
162110	170
162113	170
162610	223
162613	223
172211	170
172711	223

BDN series

Product no.	Matching DIN-Rail
6- 8- 5	FDR - 50
7-10- 4	-
9- 9- 6	FDR - 80
9-13- 5	120
10-14- 7	128
11-16- 6	150
12-22- 8	205
16-26- 9	242

BCAS series

Product no.	Matching DIN-Rail
071005	FDR - 92
080806	66
081104	92
081107	92
081108	92
081110	92
081307	110
081308	110
081807	168
081808	168
082507	235
082508	235
101007	77
101010	77
101807	150
102007	170
102307	202
121207	80
121210	80
141709	146
142309	205
151507	120
151510	120
152004	170
152007	170
152010	170
152013	170
152016	170
152510	226
152513	226
161607	137

SPCM • SPCP series

Product no.	Matching DIN-Rail
081304	FDR - 50/100
081305	50/100
081306	50/100
081308	50/100
081310	50/100
081313	50/100
101004	80
101006	80
131304	100
131305	100
131306	100
131308	100
131310	100
131313	100
SPCM	
SPCP	
131804	100/150
131805	100/150
131806	100/150
131808	100/150
131810	100/150
131813	100/150
131815	100/150
181808	150
181810	150
181813	150
181815	150
182508	150/223
182510	150/223
182515	150/223

Accessories (Optional parts)

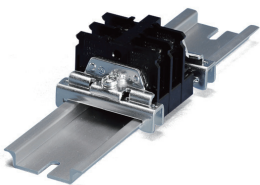

DIN-Rail stopper bracket TKR series  
See page DIN-ACC-2

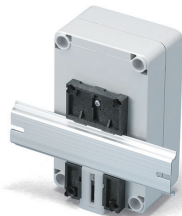

DIN-Rail mounting base DRA series  
See page DIN-ACC-1

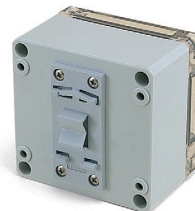

DIN-Rail mounting base DRT series  
See page DIN-ACC-1

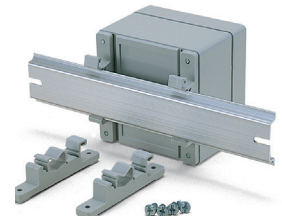

DIN-Rail mounting feet CKD series  
See page DIN-ACC-2

**DRA SERIES**

**DIN-RAIL MOUNTING BASE**

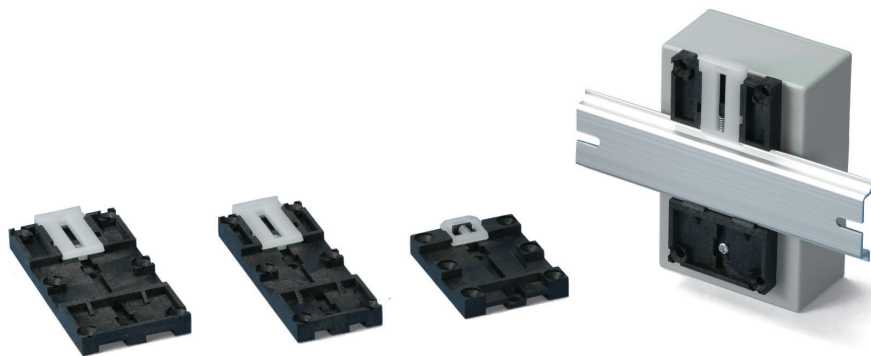

**NOTE**

Before installation, please ensure that the lever is not fully hidden behind the enclosure.

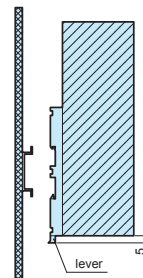

- For installation of enclosures, PCB and other parts onto a DIN rail.
- Simple installation and removal via the pull lever.

DRA-1

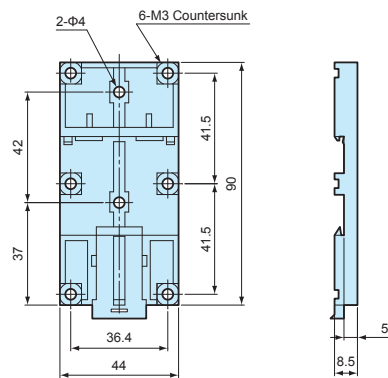

DRA-2

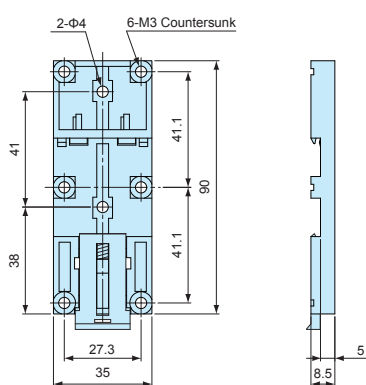

DRA-3

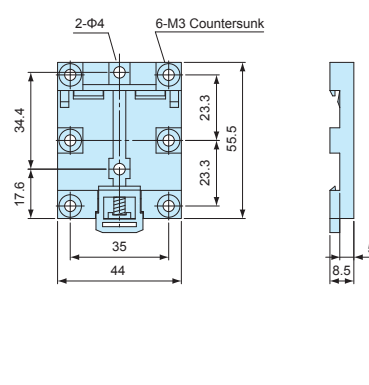

**Product no. / Dimensions**

Product no.	Material (body)	Material (lever)	Color	Weight (g)	Max load (kg)
DRA-1	PPE : SB UL94V-1	Nylon 66 UL94V-2	Black : Milky white	16.4	5
DRA-2	PPE : SB UL94V-1	Nylon 66 UL94V-2	Black : Milky white	14.5	5
DRA-3	PPE : SB UL94V-1	Nylon 66 UL94V-2	Black : Milky white	10.4	5

**DRT SERIES**

**DIN-RAIL MOUNTING BASE**

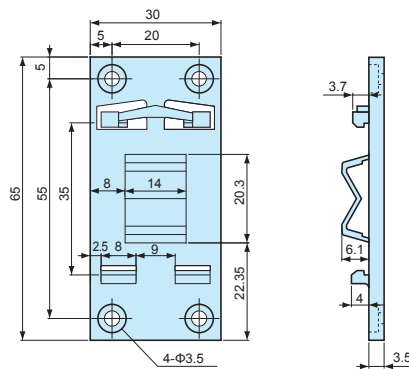
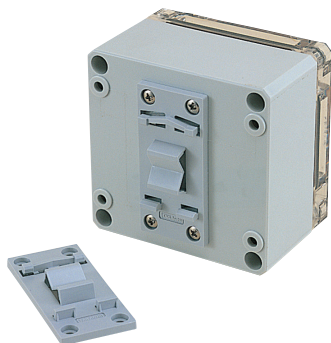

**NOTE**

Before installation, please ensure that the length (from top) of the enclosure is equal to, or less than 100mm from the center of the mounting base.

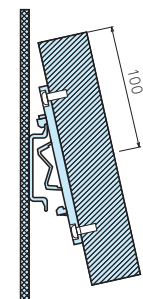

- For installation of enclosures, PCB and other parts onto a DIN rail.
- Simple installation and removal by tilting the case at an angle and sliding it in/out.

**Product no. / Dimensions**

Product no.	Material	Color	Weight (g)	Max load (kg)
DRT-1	PBT UL94V-0	Light gray	7.3	1



**CKD SERIES**

**DIN-RAIL MOUNTING FEET**

Installation example

■ DXF/DWG/PDF drawings available on our website.

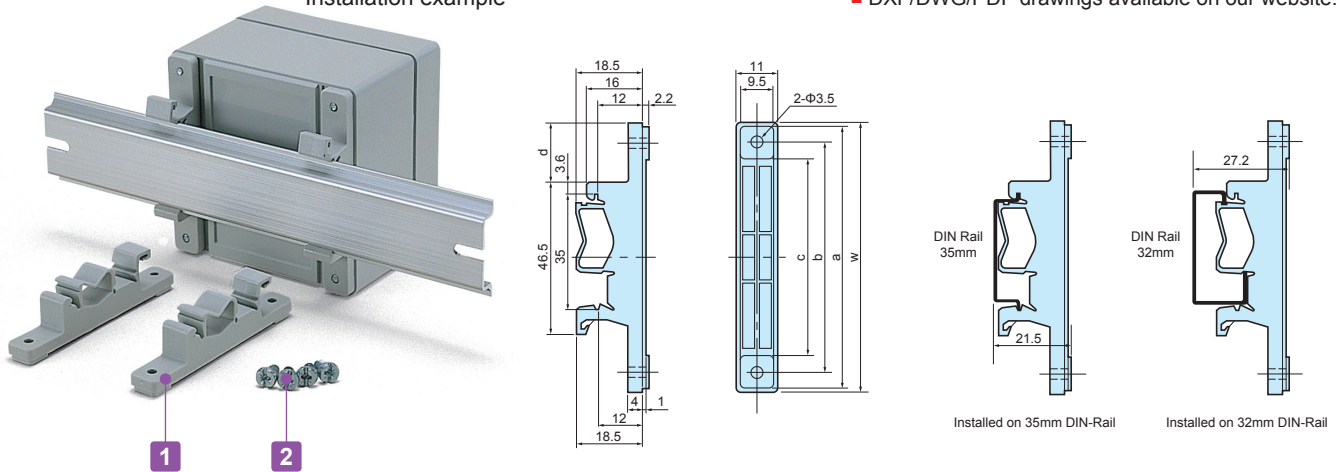

■ Mounting feet for installation of enclosures, PCB and other parts onto a DIN rail. Can be easily detached.

Technical Data
Max load : 3kg

**Components**

No.	Part name	Pcs	Material	Color / Finish
1	Mounting feet	2	Polyamide	White gray
2	Screw (special type 4.2 x 9.5)	4	Screw	Unichrome plated

**Product no. / Dimensions**

Product no.	W	a	b	c	d	Pack of
CKD- 80	77	75	66	56	17	2
CKD-120	117	115	106	96	37	2
CKD-160	157	155	147	136	57	2

**TKR SERIES**

**DIN-RAIL TERMINAL BLOCKS END STOPPER**

■ DXF/DWG/PDF drawings available on our website.

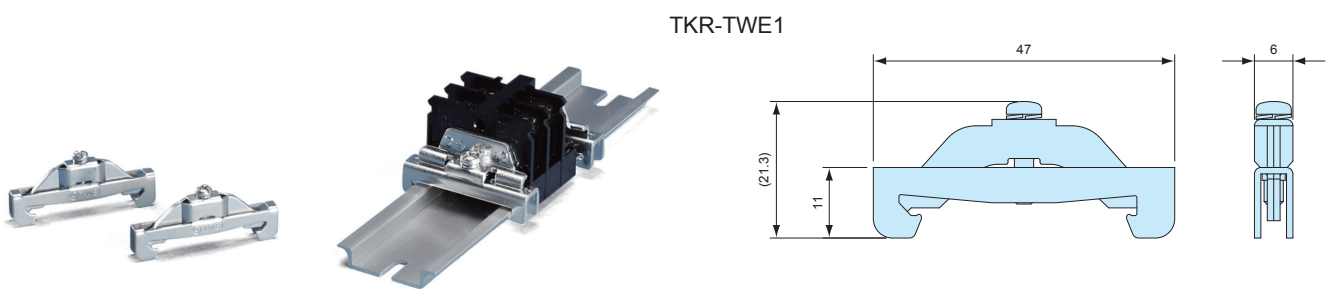

- Stopper bracket for use with 35mm DIN-rail to keep an attachment at a fixed location.
- TKR-TWE1 is used with small DIN rail attachment parts. For larger/higher attachment parts, TKR-JTXE3 is recommended for providing additional support.

**Product no. / Feature**

Product no.	Material	Color / Finish	Pack of
TKR-TWE1	Steel sheet	Trivalent chromate	2
TKR-JTXE3	Steel sheet	Trivalent chromate	2

PMF series

PROTECTIVE VENT

Pressure Equalization / Ventilation



Application Example

- Protective vent protects the enclosure from deformation by equalizing internal and external pressure differences, as well as venting the gas generated within the enclosure.
- IP68 protection class (water depth 2 meters / 60 mins) with an operating temperature range -40°C ~ +125°C allows them to be used in harsh environments.
- PMF-6B model is suitable for enclosures with capacities of up to 2.0 liters. PMF-12 and PMF-12HS models are suitable for up to 5 and 50 liters respectively.
- Recommended to be installed at the sides of the enclosure.
- Use in industrial and electrical / electronic products only; not suitable to be used in medical, food and beverage, and cosmetic industries and related industrial equipment.

PMF dimensions

Hole milling drawings

Installation drawings

■ DXF/DWG/PDF drawings available on our website.

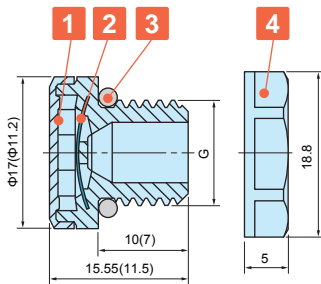

( ) values are for PMF-6B.  
Lock nut is not available for PMF-6B

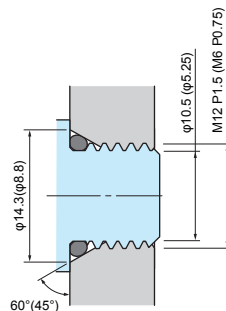

■ Recommended for prevention of O-ring deformation during tightening.  
If tightened with a lock nut, a standard through-hole is sufficient for installation.

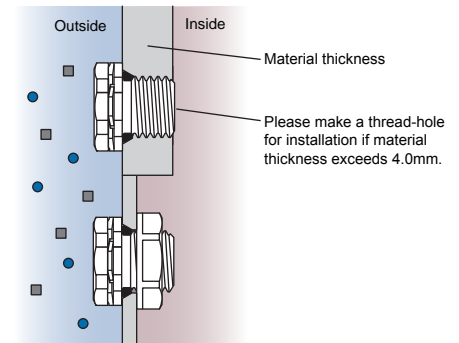

■ If used with a lock nut, material thickness should not exceed 4.0mm.

Technical Data

Product no.	PMF-6B	PMF-12	PNF-12HA
Airflow	300ml / min (dp = 7kPa)	450ml / min (dp = 7kPa)	4,000ml / min (dp = 7kPa)
Recommended torque	0.2 ~ 0.4N · m	0.6 ~ 0.8N · m	0.6 ~ 0.8N · m
Certifications	IEC60529 (Protection class test) : IP65 • IP66 • IP67 • IP68 • IP69K (Not for PMF-6B) IEC60068-2-1, 2, 14 (Heat resistance test) : - 40°C ~ +125°C (~+150°C for PMF-6B) IEC60068-2-78 (Humidity test) : 85°C • 85% humidity • 1,000 hours IEC60068-2-11, 52 (Salt spray test) IEC60068-2-64 (Vibration test) GR-3108-CORE (Corrosive gas test) UL94V-0 (Flame-resistant) • UL746C f1		

Product no. / Dimensions

Product no.		Material				G		Lock nut
● Light gray	● Black	1 Housing	2 Filter	3 O-ring	4 Lock nut	Thread size	Mount hole	SW
—	PMF- 6B	PA6 / 66	PTFE	Silicone	—	M6 x P0.75	—	—
PMF-12S	PMF-12B	PA66 / 6	PTFE	Silicone	PA66 (UL94V-2)	M12 x P1.5	Φ12.2	17
PMF-12HAS	PMF-12HAB	PA66 / 6	PTFE	Silicone	PA66 (UL94V-2)	M12 x P1.5	Φ12.2	17

# PMF-32S

# LARGE PROTECTIVE VENT

## Pressure Equalization / Ventilation



Application Example

- Maintaining high airflow for large enclosures in an outdoor environment.
- Protective vent protects the enclosure from deformation by equalizing internal and external pressure differences, as well as venting the gas generated within the enclosure.
- Simple and flat design allows it to be used on a wide variety of enclosure types.
- IP68 protection class rated with an operating temperature range of -40°C ~ +125°C allows it to be used in harsh environments.
- Compliant with Solar industry testing IEC62108 standards.
- Recommended to be installed at the sides of the enclosure.
- Use in industrial and electrical / electronic products only; not suitable to be used in medical, food and beverage, and cosmetic industries and related industrial equipment.

### PMF-32 dimensions

■ DXF/DWG/PDF drawings available on our website.

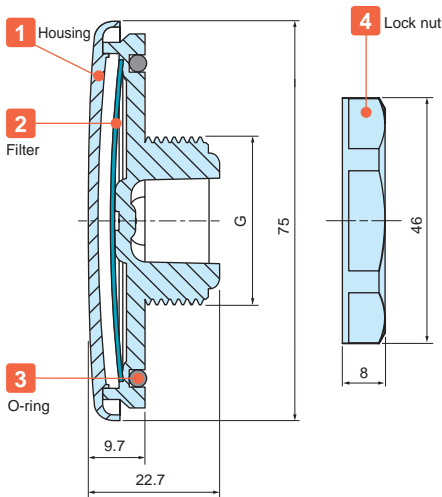

### Hole milling drawings

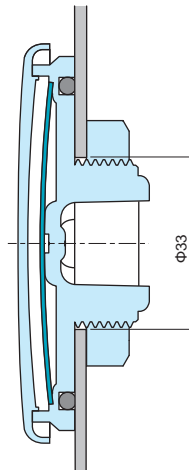

### Installation drawings

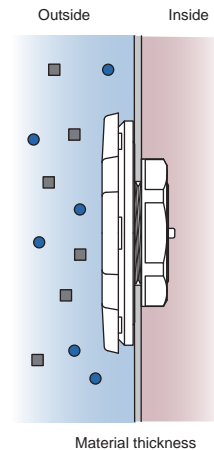

■ If used with a lock nut, material thickness should not exceed 5.0mm.

### Technical Data

<b>Airflow</b>	16ℓ / min (dp = 1.2kPa)
<b>Recommended torque</b>	5 N · m
<b>Certifications</b>	IEC529, 2nd (Protection class test) : IP66 · IP67 · IP68 · IP69K IEC60068-2-1, 2, 14 (Heat resistance test) : - 40°C ~ +125°C IEC60068-2-78 (Humidity test) : 85°C · 85% humidity · 1,000 hours IEC60068-2-11, 52 (Salt spray test) IEC60068-2-64 (Vibration test) IEC62108, 10.8 · 9 (Solar industry test) : Freezing · High temperature tes · Hail impact test GR-3108-CORE (Corrosive gas test) UL94V-0 (Flame-resistant) · UL746C f1

### Product no. / Dimensions

Product no.	Material				G			Lock nut SW
	1 Housing	2 Filter	3 O-ring	4 Lock nut	Thread size	Thread diameter	Mount hole	
PMF-32S	Polycarbonate	PTFE	Silicone	PA66	M32 x P1.5	φ32	φ33	41.5

VE8 series

ADHESIVE PROTECTIVE VENT FILTER



Technical Data
Protection class : Dustproof IP6X Waterproof IPX4, IPX7
Airflow: 3,300ml/min/cm2 (at 7Kpa)
Operating temperature: -40°C ~ +100°C

- Improved airflow of 3,300ml/min/cm2 as compared to previous VSC series.
- Vent filter protects the enclosure from deformation by equalizing internal and external pressure differences, as well as venting the gas generated within the enclosure.
- Allows water vapor molecules to diffuse through the microporous membrane.
- Highly water and oil repellent membrane protects electronic components from water, corrosive liquids, salts and dust.
- Easy installation adhesive filter.
- Recommended to be adhered onto flat plastic or metallic surfaces.

CAUTION

- Install only on the inner surface of the case / box with the membrane and adhesive side facing outwards.
- An initial period of 24 hours is required for the adhesive to properly bond to the surface. Avoid using the vent filter with a heavy load.
- Please do not adhere onto the top-side of enclosures. Rain water etc. will collect on the filter, which will weaken the adhesive seal and prevent proper ventilation.
- After degreasing and cleaning, adhere the filter without touching the center part of the vent filter.
- Use in industrial and electrical / electronic products only; not suitable to be used in medical, food and beverage, and cosmetic industries and related industrial equipment.

VE8 drawings

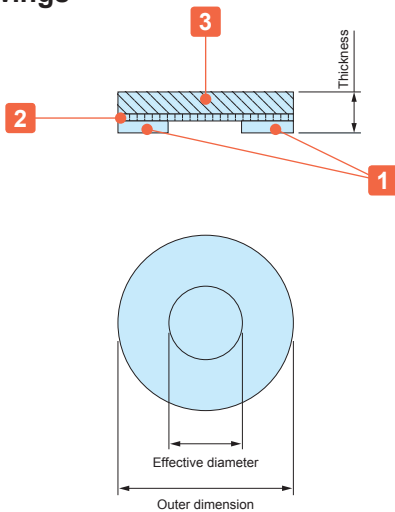

Installation drawings

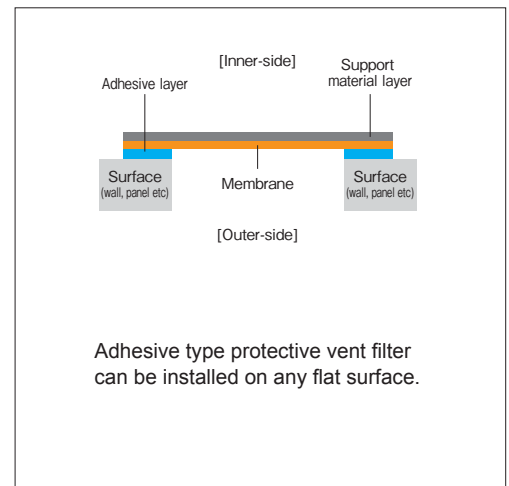

Components

No.	Part name	Material	Color
1	Adhesive	Acrylic adhesive	Transparent
2	Filter	ePTFE (Oil-repellent type)	White
3	Support material	Polyester fabric	White

Product no. / Dimensions

Product no.	Outer dimension (Φ-mm)	Effective diameter (Φ-mm)	Thickness (mm)	Sales unit
VE80308	7.6	3.3	0.26	8 pcs (per pack)
VE80814	14.0	8.0	0.26	4 pcs (per pack)
VE81221	21.5	12.5	0.26	4 pcs (per pack)
<b>NEW</b> VE82029S	29.0	20.0	0.35	2 pcs (per pack)
VE80308-S	7.6	3.3	0.26	96 pcs (per sheet)
VE80814-S	14.0	8.0	0.26	56 pcs (per sheet)
VE81221-S	21.5	12.5	0.26	20 pcs (per sheet)
<b>NEW</b> VE82029S-S	29.0	20.0	0.35	10 pcs (per sheet)

V series

VENTILATION LOUVER



- Recommended for condensation prevention and heat dissipation.
- 2 models available : ABS V60, V80 match the color for BCAP and BCAR series, and polycarbonate V60S and V80S match the color for BCPC, BCPK, and BCAR series.
- Suitable to be used on a variety of enclosure types, series and models.

V dimensions

■ DXF/DWG/PDF drawings available on our website.

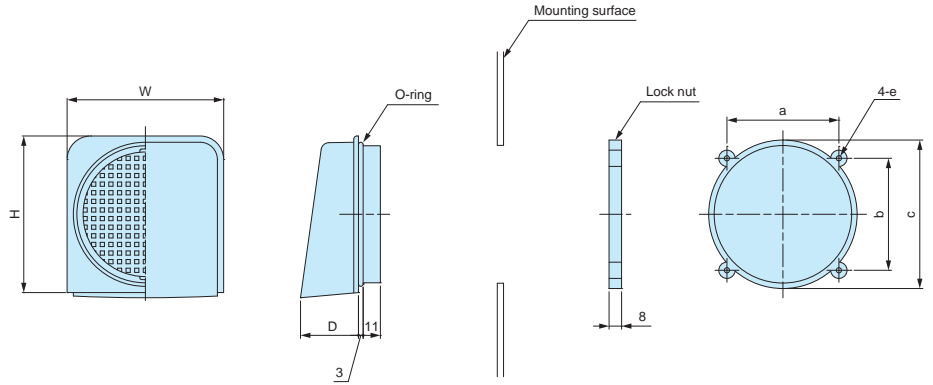

Product no. / Dimensions

Product no.	Material	Color	Mount hole	W	H	D	a	b	c	e
V60	ABS	White gray	Φ63	74	74	31.8	50.5	50.5	70	Φ3.8
V80	ABS	White gray	Φ88	100	100	37	71.5	71.5	94.8	Φ3.3
V60S	Polycarbonate	Light gray	Φ63	74	74	31.8	50.5	50.5	70	Φ3.8
V80S	Polycarbonate	Light gray	Φ88	100	100	37	71.5	71.5	94.8	Φ3.3

■ O-ring material : NBR / Black

VF series

VENTILATION PARTS

VF dimensions

■ DXF/DWG/PDF drawings available on our website.

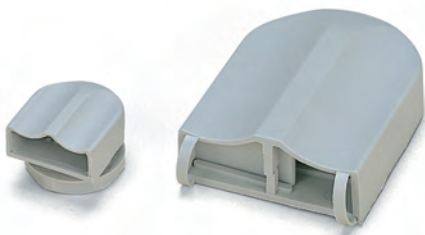

VF-1

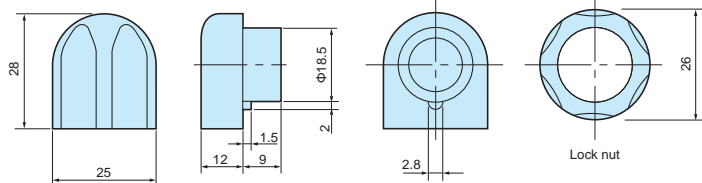

Hole layout for mounting

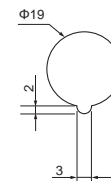

VF-2

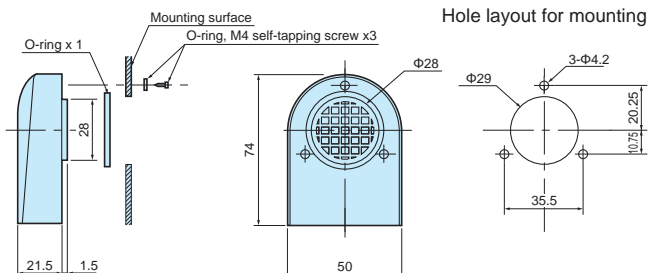

Hole layout for mounting

Technical Data

Protection class : VF-1 IP33  
VF-2 IP24

Product no. / Dimensions

Product no.	Material / Color
VF-1	Polyamide / White gray
VF-2	Polyamide / White gray



- Weatherproof cable gland equipped with high ultraviolet and degradation resistant silicone sealing insert and O-ring.
- Recommended to use outdoors where waterproofing is critical.
- IP67 protection class.

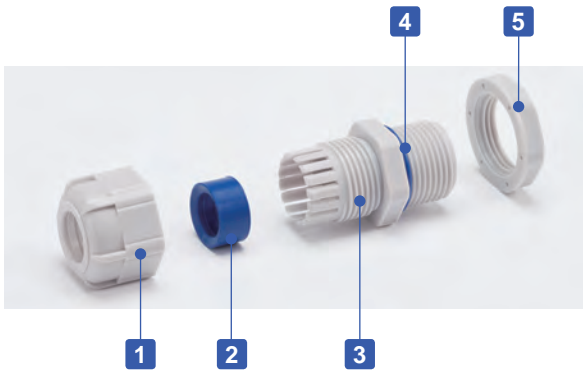

Components

■ PA = Polyamide

No.	Part name	Material
1	Cap	PA66 UL94V-2
2	Sealing insert	Silicone
3	Connector	PA66 UL94V-2
4	O-ring	Silicone
5	Lock nut	PA66 UL94V-2

RMW dimensions

■ DXF/DWG/PDF drawings available on our website.

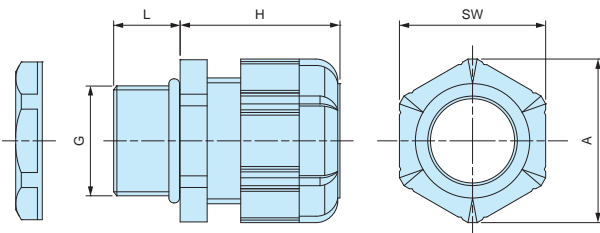

Technical Data

Protection class: IP67  
Operating temperature: -20°C ~ +80°C

- Lock nut is not included for RMW10S-6.  
Please drill a proper thread hole into the enclosure for installation.

Product no. / Dimensions

Product no.		G		Cable range		L	H Max	SW	A	Pack of
● Black	● Light gray	Thread size	Mounting hole	Min	Max					
RMW8L-2.5B	RMW8L-2.5S	M8x1.25	Φ8.2	1	2.5	13	19.5	11.8	13.5	1
RMW8L-4B	RMW8L-4S	M8x1.25	Φ8.2	2.5	4	13	19.5	11.8	13.5	1
RMW10S-6B	RMW10S-6S	M10x1.5	—	3	6	8	20.5	13	14.4	1
RMW10L-6B	RMW10L-6S	M10x1.5	Φ10.2	3	6	13	20.5	13	14.4	1
RMW12S-7B	RMW12S-7S	M12x1.5	Φ12.2	3.5	7	9	20.5	16	17.6	1
RMW12L-7B	RMW12L-7S	M12x1.5	Φ12.2	3.5	7	14.5	20.5	16	17.7	1
RMW16S-8B	RMW16S-8S	M16x1.5	Φ16.2	4	8	9	23.5	19	21	1
RMW16L-8B	RMW16L-8S	M16x1.5	Φ16.2	4	8	15	24	19	21	1
RMW20S-12B	RMW20S-12S	M20x1.5	Φ20.2	6	12	10	29	24	26.2	1
RMW20L-12B	RMW20L-12S	M20x1.5	Φ20.2	6	12	15	28.5	24	26.2	1
RMW25L-17B	RMW25L-17S	M25x1.5	Φ25.2	11	17	15	35	33	36.2	1
RMW32L-21B	RMW32L-21S	M32x1.5	Φ32.3	13	21	15	38	36	39.5	1
RMW40L-27B	RMW40L-27S	M40x1.5	Φ40.3	18	27	18	43.5	45.7	50.5	1
RMW50L-38B	RMW50L-38S	M50x1.5	Φ50.4	27	38	20	50.5	60	66.5	1
RMW10L-6B-P	RMW10L-6S-P	M10x1.5	Φ10.2	3	6	13	20.5	13	14.4	100
RMW12S-7B-P	RMW12S-7S-P	M12x1.5	Φ12.2	3.5	7	9	20.5	16	17.6	100
RMW12L-7B-P	RMW12L-7S-P	M12x1.5	Φ12.2	3.5	7	14.5	20.5	16	17.7	100
RMW16S-8B-P	RMW16S-8S-P	M16x1.5	Φ16.2	4	8	9	23.5	19	21	100
RMW16L-8B-P	RMW16L-8S-P	M16x1.5	Φ16.2	4	8	15	24	19	21	100
RMW20S-12B-P	RMW20S-12S-P	M20x1.5	Φ20.2	6	12	10	29	24	26.2	100
RMW20L-12B-P	RMW20L-12S-P	M20x1.5	Φ20.2	6	12	15	28.5	24	26.2	100

# RMW series silicone sealing insert weatherproof test report

Object: Cut into a piece of the silicone sealing insert from RMW series and attach it onto an aluminium plate.  
 For comparison, NBR sealing insert from our RM and EPDM sealing insert from another manufacturer is also attached for comparison purposes.



Before

After

### Testing conditions

**Equipment :** 7.5kW Super Xenon Weather Meter SX75 (Suga Test Instruments Co., Ltd.- <http://www.sugatest.co.jp/english/>)  
**Conditions :** JIS B7754 : 1991  
 Testing with an authorized Xenon arc lamp weathering test equipment under the conditions denoted below.  
 Irradiance : 180W/m<sup>2</sup> at 300-400nm  
 Black Panel Temperature : 63±3°C Humidity Range : 50±10%  
 Cycle Conditions : 120 minutes cycle (18 minutes irradiation + water spray - 102 minutes irradiation)  
**Time period :** 2,000 hours (equivalent to a period of 4 years under natural conditions)  
**Total radiant exposure :** 1296MJ/m<sup>2</sup>

### Test result (visual / touch inspection)

**Silicone sealing insert material :** No cracks, no gloss transition, no powder - no appearance change at all. Flexibility remains unchanged.

Before



After



**NBR material from our RM series :** Lost glossiness on the surface and material is stiffened.

Before



After



**EPDM material from weatherproof cable gland of another manufacturer :** Cracked, color drastically faded and powder appeared on the surface.

Before



After

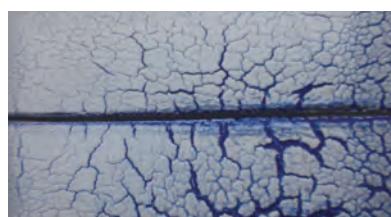

# RM series POLYAMIDE CABLE GLAND

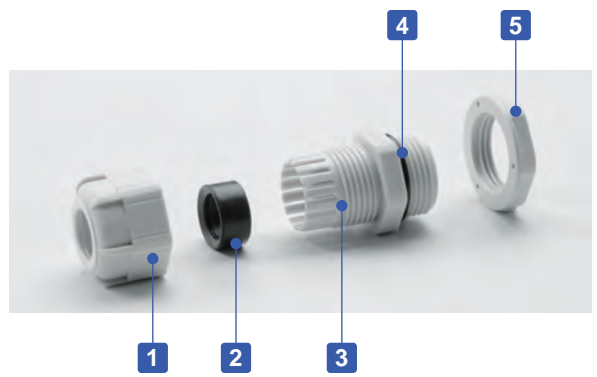

- Low cost cable glands made from polyamide material.
- Wide selection, for M8 ~ M63, suitable for  $\Phi 1\text{mm} \sim \Phi 44\text{ mm}$  cable.
- High oil resistant NBR rubber sealing and O-ring.
- IP67 protection class.

### Components

■ PA = Polyamide

No.	Part name	Material
1	Cap	PA66 UL94V-2
2	Sealing insert	NBR
3	Connector	PA66 UL94V-2
4	O-ring	NBR
5	Lock nut	PA66 UL94V-2

### RM dimensions

■ DXF/DWG/PDF drawings available on our website.

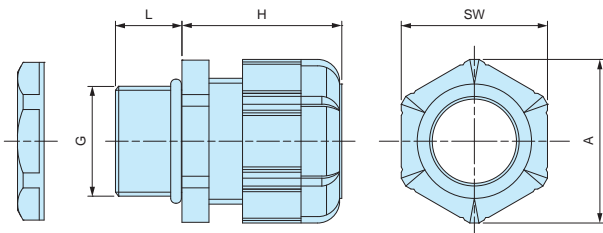

Technical Data
Protection class: IP67
Operating temperature: -20°C ~ +80°C

- Lock nut is not included for RM8S-2.5, 8S-4, and 10S-6 models.  
Please drill a proper thread hole into the enclosure for installation.

### Product no. / Dimensions

Product no.		G		Cable range		L	H Max	SW	A	Pack of
● Black	● Light gray	Thread size	Mounting hole	Min	Max					
RM8S-2.5B	RM8S-2.5S	M8x1.25	—	1	2.5	7.5	19.5	11.8	13.5	1
RM8L-2.5B	RM8L-2.5S	M8x1.25	$\Phi 8.2$	1	2.5	13	19.5	11.8	13.5	1
RM8S-4B	RM8S-4S	M8x1.25	—	2.5	4	7.5	19.5	11.8	13.5	1
RM8L-4B	RM8L-4S	M8x1.25	$\Phi 8.2$	2.5	4	13	19.5	11.8	13.5	1
RM10S-6B	RM10S-6S	M10x1.5	—	3	6	8	20.5	13	14.4	1
RM10L-6B	RM10L-6S	M10x1.5	$\Phi 10.2$	3	6	13	20.5	13	14.4	1
RM12S-7B	RM12S-7S	M12x1.5	$\Phi 12.2$	3.5	7	9	20.5	16	17.6	1
RM12L-7B	RM12L-7S	M12x1.5	$\Phi 12.2$	3.5	7	14.5	20.5	16	17.7	1
RM16S-8B	RM16S-8S	M16x1.5	$\Phi 16.2$	4	8	9	23.5	19	21	1
RM16L-8B	RM16L-8S	M16x1.5	$\Phi 16.2$	4	8	15	24	19	21	1
RM20S-12B	RM20S-12S	M20x1.5	$\Phi 20.2$	6	12	10	29	24	26.2	1
RM20L-12B	RM20L-12S	M20x1.5	$\Phi 20.2$	6	12	15	28.5	24	26.2	1
RM25L-17B	RM25L-17S	M25x1.5	$\Phi 25.2$	11	17	15	35	33	36.2	1
RM32L-21B	RM32L-21S	M32x1.5	$\Phi 32.3$	13	21	15	38	36	39.5	1
RM40L-27B	RM40L-27S	M40x1.5	$\Phi 40.3$	18	27	18	43.5	45.7	50.5	1
RM50L-38B	RM50L-38S	M50x1.5	$\Phi 50.4$	27	38	20	50.5	60	66.5	1
RM63L-44B	RM63L-44S	M63x1.5	$\Phi 63.4$	37	44	20	53	68	75.5	1
RM10L-6B-P	RM10L-6S-P	M10x1.5	$\Phi 10.2$	3	6	13	20.5	13	14.4	100
RM12S-7B-P	RM12S-7S-P	M12x1.5	$\Phi 12.2$	3.5	7	9	20.5	16	17.6	100
RM12L-7B-P	RM12L-7S-P	M12x1.5	$\Phi 12.2$	3.5	7	14.5	20.5	16	17.7	100
RM16S-8B-P	RM16S-8S-P	M16x1.5	$\Phi 16.2$	4	8	9	23.5	19	21	100
RM16L-8B-P	RM16L-8S-P	M16x1.5	$\Phi 16.2$	4	8	15	24	19	21	100
RM20S-12B-P	RM20S-12S-P	M20x1.5	$\Phi 20.2$	6	12	10	29	24	26.2	100
RM20L-12B-P	RM20L-12S-P	M20x1.5	$\Phi 20.2$	6	12	15	28.5	24	26.2	100
RM25L-17B-P	RM25L-17S-P	M25x1.5	$\Phi 25.2$	11	17	15	35	33	36.2	100





RSP series

STRAIN RELIEF CABLE GLAND



- New sizes added for a total of 14 models available for selection.
- Strain relief cap protects cables by preventing it from bending beyond its limit and breaking.
- Economical price but high waterproofing capability equivalent to IP67.

Technical Data
Protection class : Equivalent to IP67*
Operating temperature : -20°C ~ +80°C

\*In-house test

RSP dimensions

■ DXF/DWG/PDF drawings available on our website.

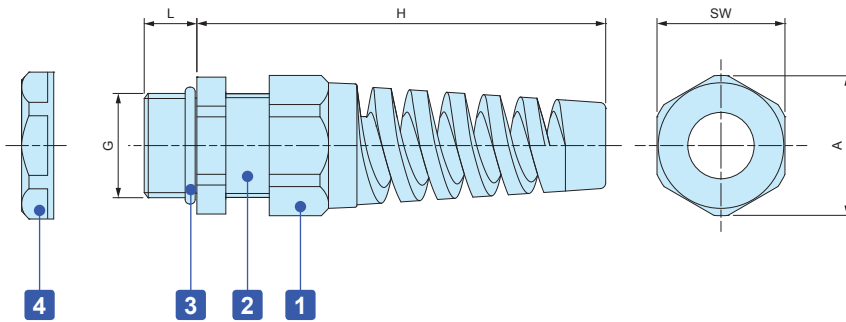

Components

■ PA = Polyamide

No.	Part name	Material
1	Strain relief cap	PA66 UL94V-2
-	Sealing insert	NBR
2	Connector	PA66 UL94V-2
3	O-ring	NBR
4	Lock nut	PA66 UL94V-2

Product no. / Details

Product no.		G		Cable range		L	H	SW	A	Pack of
● Black	● Light gray	Thread size	Mounting hole	Min	Max					
<b>NEW</b> RSP 8-2.5B	<b>NEW</b> RSP 8-2.5S	M 8×1.25	Φ 8.2	1	2.5	10.5	48	12.1	13.8	1
<b>NEW</b> RSP 8-4B	<b>NEW</b> RSP 8-4S	M 8×1.25	Φ 8.2	2.5	4	10.5	48	12.1	13.8	1
<b>NEW</b> RSP10-6B	<b>NEW</b> RSP10-6S	M10×1.5	Φ10.2	3	6	12.2	54	13.1	14.5	1
RSP12-6B	RSP12-6S	M12×1.5	Φ12.2	3.5	6	9	62	16	17	1
RSP16-8B	RSP16-8S	M16×1.5	Φ16.2	4	8	9	69	19.5	21	1
RSP20-11B	RSP20-11S	M20×1.5	Φ20.2	6	11	10	82	24	26	1
RSP25-16B	RSP25-16S	M25×1.5	Φ25.2	11	16	12	102	33	36	1



- High water protection IP68 (1bar / 30min) polyamide cable gland.
- Wide selection, for M8 ~ M50, suitable for  $\Phi$ 2.5mm ~  $\Phi$ 42 mm cable.
- Super tough and superior heat resistant PA6GF (glass fiber filled PA6) material on cap and connector.
- Safer halogen free, eco-friendly product.

Technical Data
Protection class: IP68 1bar / 30min
Operating temperature: -20°C ~ +100°C
Compliant with EN50262 Ver. A

**AG series**

Thicker sealing insert evenly hold a cable by having a larger holding area. Remains durable even after repeated tightening / loosening.

**Lamellar insert type**

If over-tightened, it can cause the rubber bush or cable to deform, which can allow water to seep in.

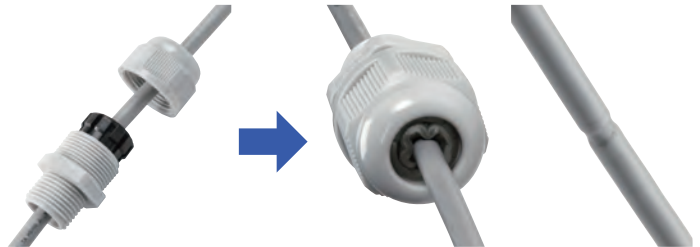
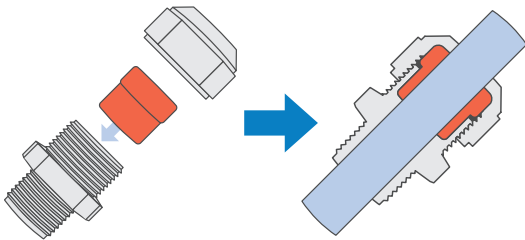

**Components**

■ PA6GF = Polyamide6 Glass Fiber Filled

No.	Part name	Material
1	Cap	PA6GF
2	Sealing insert	TPE
3	Connector	PA6GF
4	Lock nut	PA6

- Lock nut is not included for M8 and M10 sizes. Please drill a proper thread hole into the enclosure for installation.

- Proper tightening torque varies by each cable diameter. Tighten the cap until top of the sealing insert forms a small bead between the cap and the cable.



■ No optional sealing washer is required when installing on an even surface because of the built-in waterproof rib.

■ An optional sealing washer is required when installing on an uneven surface. (See website for more information on the optional sealing washer)

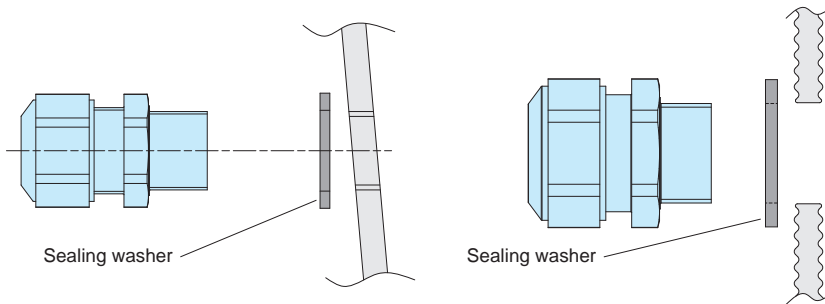

**AG dimensions**

■ DXF/DWG/PDF drawings available on our website.

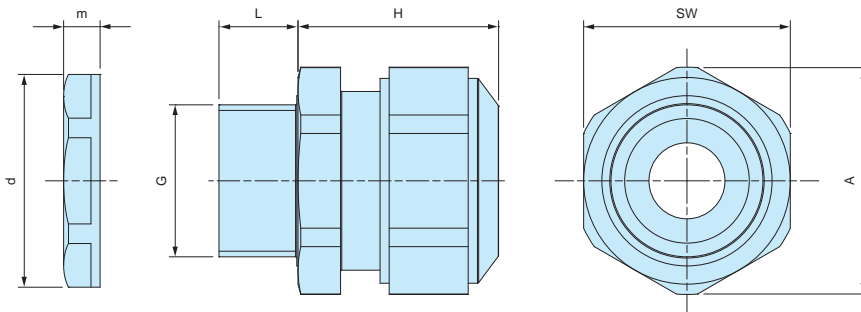

■ Lock nut is not included for M8 and M10 sizes. Please drill a proper thread hole into the enclosure for installation.

**Product no. / Dimensions**

Product no.		G		Cable range		L	H Max	SW	A	d	m	Pack of
● Black	● Light gray	Thread size	Mounting hole	Min	Max							
AG8-3.5B	AG8-3.5S	M8x1.0	—	2.5	3.5	10	17	12	13.2	—	—	1
AG8-5B	AG8-5S	M8x1.0	—	3.5	4.7	10	17	12	13.2	—	—	1
AG10-6B	AG10-6S	M10x1.0	—	4	6	10	19	15	16.5	—	—	1
AG12-5B	AG12-5S	M12x1.5	Φ12.2	3.5	4.7	12	23.5	17	18.7	18.8	5	1
AG12-6.5B	AG12-6.5S	M12x1.5	Φ12.2	5	6.5	12	23	17	18.7	18.8	5	1
AG12-8B	AG12-8S	M12x1.5	Φ12.2	6.5	7.8	12	23	17	18.7	18.8	5	1
AG16-10B	AG16-10S	M16x1.5	Φ16.2	8	10	12	26	21	23.1	24.3	5	1
AG20-15B	AG20-15S	M20x1.5	Φ20.2	11	15	13	27	27	29.7	29	6	1
AG25-16B	AG25-16S	M25x1.5	Φ25.2	12.5	16	13	34	34	37.4	36	6.7	1
AG25-20B	AG25-20S	M25x1.5	Φ25.2	16	20	13	34	34	37.4	36	6.7	1
AG32-25.5B	AG32-25.5S	M32x1.5	Φ32.3	21	25.5	15	36	41	45.6	46	8	1
AG40-28.5B	AG40-28.5S	M40x1.5	Φ40.3	24	28.5	15	41	50	55.4	53.5	9	1
AG40-33B	AG40-33S	M40x1.5	Φ40.3	28.5	33	15	41	50	55.4	53.5	9	1
AG50-37B	AG50-37S	M50x1.5	Φ50.4	33	37	16	45	60	65.5	66	9.6	1
AG50-42B	AG50-42S	M50x1.5	Φ50.4	37	42	16	45	60	65.5	66	9.6	1

**SP SERIES**

**SEALING PLUG**



**SP dimensions**

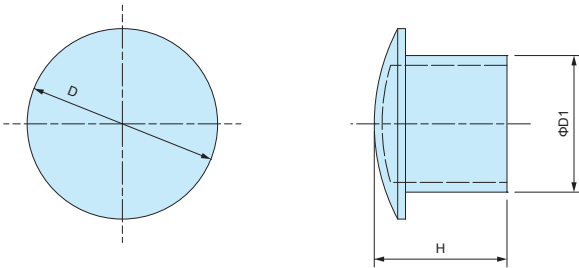

■ Material : Nylon

- Sealing plug for cable glands when not in use.
- Maintain a waterproof seal when plugged into the sealing insert on cable glands.

**Product no. / Dimensions**

Product no.	D	D1	H	Suitable cable glands	Pack of
SP-12	10.2	6	15.5	RMW12, RM12, RMW16, RM16, RPG7, RPG9	10
SP-16	15.6	9.5	15.5	RMW20, RM20, RPG11, RPG13.5	10
SP-20	19.6	13.5	16.5	RPG16	10
SP-25	24.4	17.5	17	RMW25, RM25, RMW32, RM32, RPG21	5
SP-40	32.5	24.5	17.5	RMW40, RM40, RPG29	5
SP-50	47.2	38.9	17.6	RMW50, RM50	5

# AGP SERIES

# SEALING WASHER for AG • AGSP

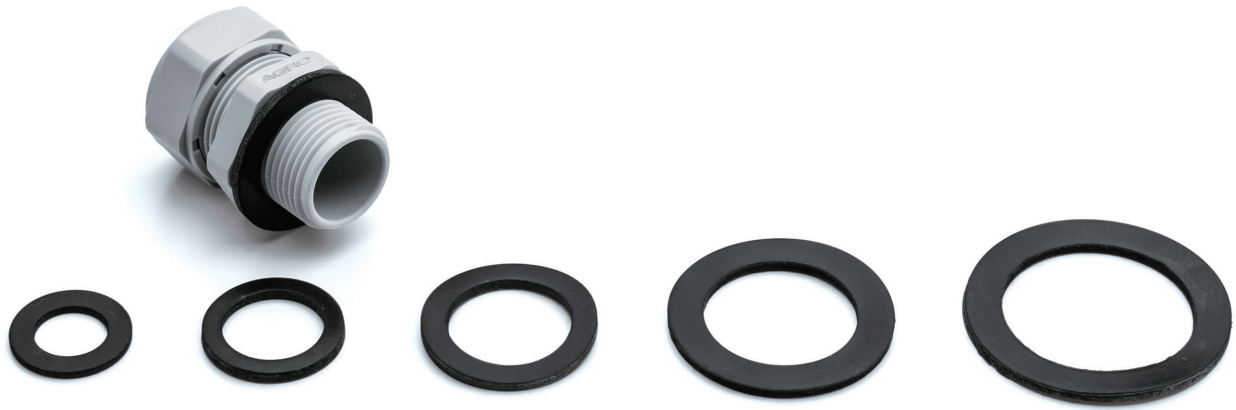

- Sealing washer for AG • AGSP series.
- Made from oil resistant NBR material.
- Use in the case of installation on a rough or uneven surfaces.
- Selectable in 7 sizes (from M12 to M50)
- Sealing washer is not necessary for installation on flat surfaces.

## AGP Dimensions

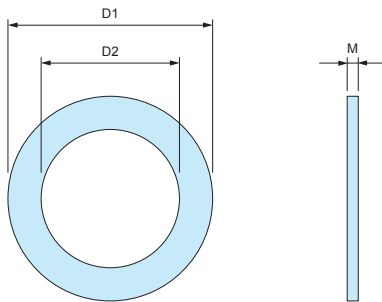

- Material : NBR

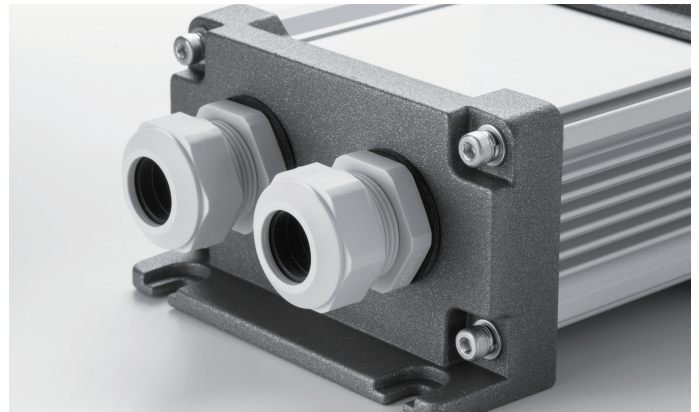

### Product no. / Dimensions

Product no.	D1	D2	M	Suitable cable gland	Pack of
AGP-12	20	12	1.6	AG12 / AGSP12-6.5	10
AGP-16	23.5	16.5	2.0	AG16 / AGSP16-8	10
AGP-20	29	20	2.0	AG20 / AGSP20-12	10
AGP-25	37	25	2.0	AG25	10
AGP-32	44	32	2.2	AG32	5
AGP-40	52	40	2.2	AG40	5
AGP-50	64	50	3.1	AG50	5