

構成内容 / Components				
No.	名称 / Part name	数量 / Pcs	材質 / Material	色・表面処理 / Color・Finish
1	ヒートシンク側板 Heat-sink side plate	2	アルミ押出材 A6063S-T5 Extruded aluminium A6063S-T5	シルバーアルマイト, ブラックアルマイト Silver anodized, Black anodized
2	パネル Panel	2	アルミ押出材 A6063S-T5 Extruded aluminium A6063S-T5	ヘアラインシルバーアルマイト, ヘアラインブラックアルマイト Hairline brushed Silver anodized, Hairline brushed Black anodized
3	天底板 Top cover, Bottom cover	2	アルミ板 A1050P Aluminium A1050P	ヘアラインシルバーアルマイト, ヘアラインブラックアルマイト Hairline brushed Silver anodized, Hairline brushed Black anodized
4	固定金具 / Corner support	4	鋼板 SPCC / Steel SPCC	三価クロメート / Trivalent chromate
5	ゴム足 / Rubber feet	4	ポリウレタン / Polyurethane	ブラック / Black
6	取付ビス (M3 x 6 サラ) Screw (M3 - 6 Countersunk)	16	鉄 Steel	ニッケルメッキ, 三価黒クロメート Nickel plated, Black trivalent chromate
7	パネル取付ビス(十字穴台形ビスM3 x 5) Screw(Original trapezoid head M3 - 5)	12	鉄 Steel	ニッケルメッキ, 三価黒クロメート Nickel plated, Black trivalent chromate

* ゴム足は任意の場所に貼り付けできます。
* Adhesive rubber feet included.

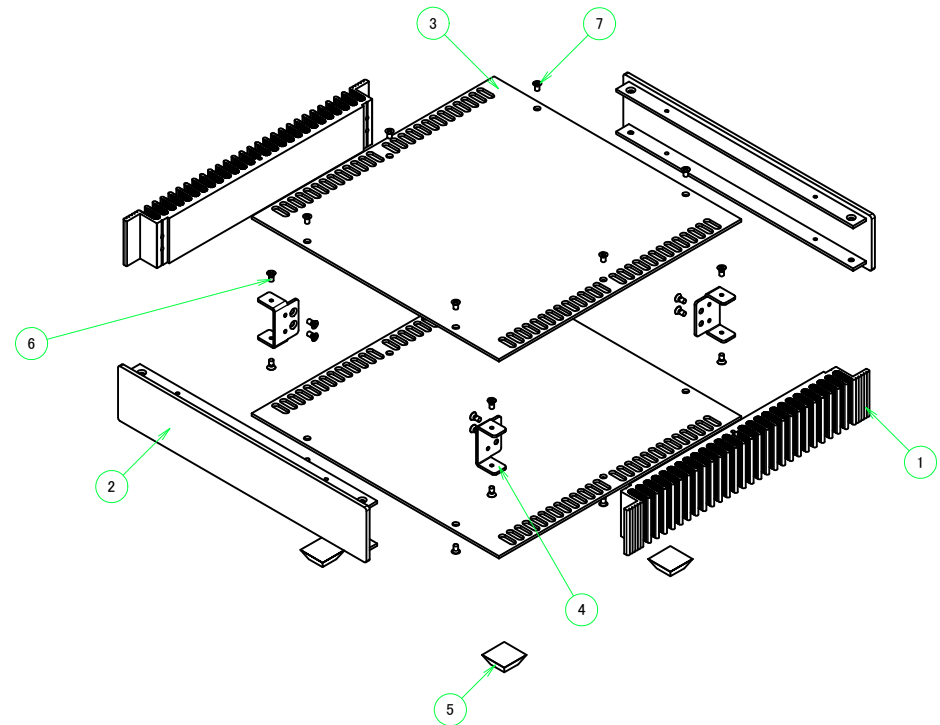

色仕様(型番末尾□) / Color type (End of product number□)	
記号 / Code	色 / Color
S S	シルバー / Silver
B B	ブラック / Black

株式会社タカチ電機工業 TAKACHI ELECTRONICS ENCLOSURE CO., LTD.			品名/Title 縦型ヒートシンクケース HEAT-SINK ALUMINIUM ENCLOSURE	尺度/Scale 1 / 5
承認/Approved 中根	検図/Checked 王	製図/Created 野村	型番/Product number HY88-43-23□	
			作成日/Date 2023/09/28	

パネル2側
Rear panel side



ヒートシンク側板1側
Heat-sink side plate1 side

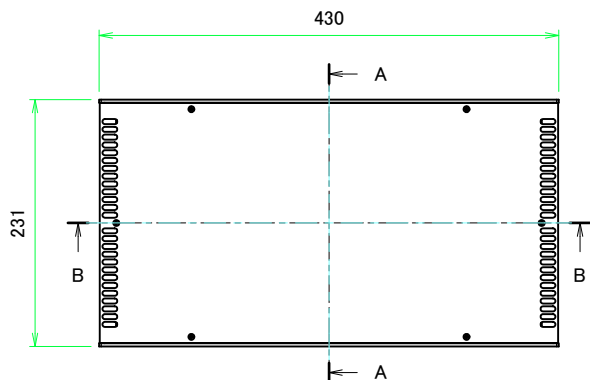
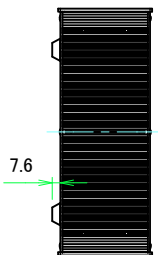

ヒートシンク側板2側
Heat-sink side plate2 side

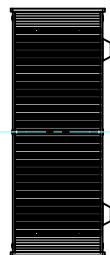

A-A (1:5)

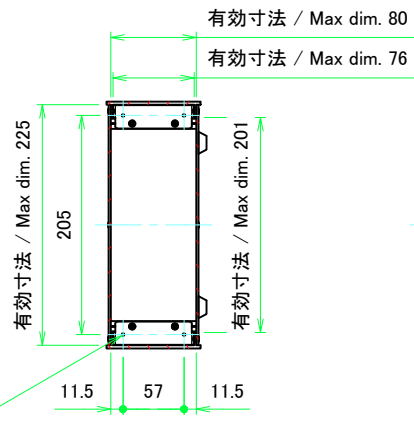

8-M3(シャーシ取付用)
8-M3 (Hole for mounting plate)

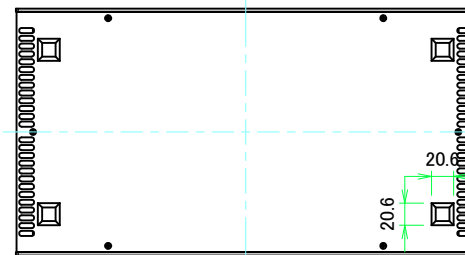

パネル1側
Front panel side



B-B (1:5)

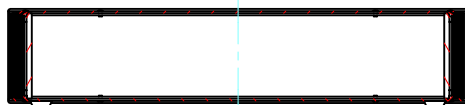

有効寸法 / Max dim. 386

株式会社タカチ電機工業 TAKACHI ELECTRONICS ENCLOSURE CO., LTD.			品名/Title 縦型ヒートシンクケース HEAT-SINK ALUMINIUM ENCLOSURE	尺度/Scale 1:5
承認/Approved 中根	検図/Checked 王	製図/Created 野村	型番/Product number HY88-43-23□	
			作成日/Date 2017/06/05	2 / 5

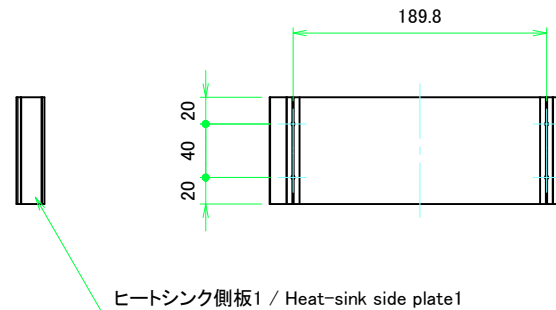
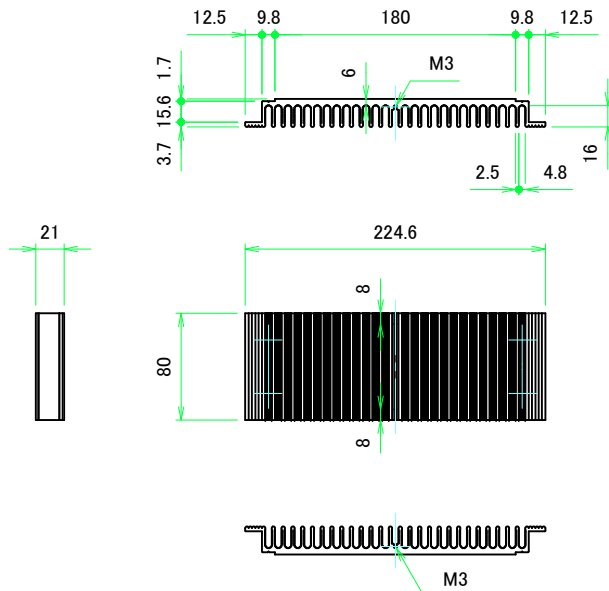

ヒートシンク側板1 / Heat-sink side plate1

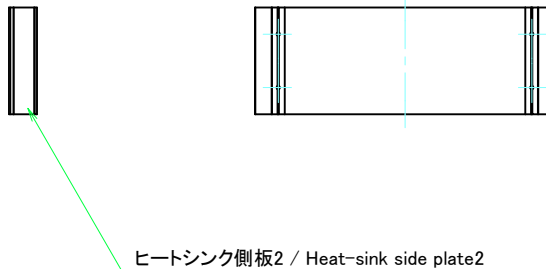
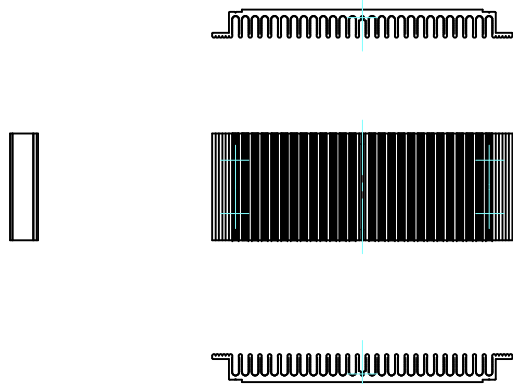



ヒートシンク側板2 / Heat-sink side plate2

■テクニカルデータ / Technical Data■

熱抵抗値 / Thermal resistance : 1.49 °C / W

*熱抵抗値はフィンが地面に垂直、温度上昇60°Cの時の値

*Thermal resistance calculation is based on the fins being perpendicular to the ground with temperature at 60°C

 株式会社タカチ電機工業 <small>TAKACHI ELECTRONICS ENCLOSURE CO., LTD.</small>			品名/Title ヒートシンク側板 Heat-sink side plate	 尺度/Scale 1:4
承認/Approved 中根	検図/Checked 王	製図/Created 野村	型番/Product number H88 - D230	
			作成日/Date 2017/06/05	3 / 5

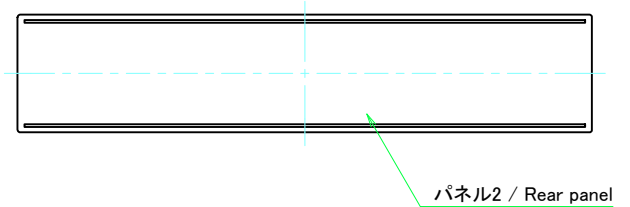
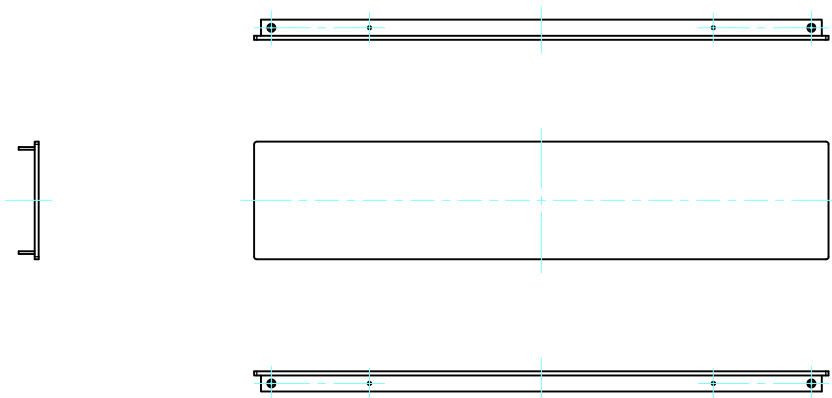
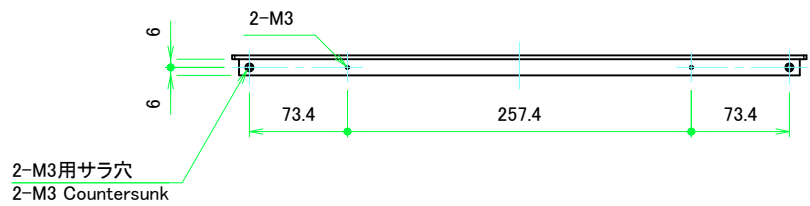
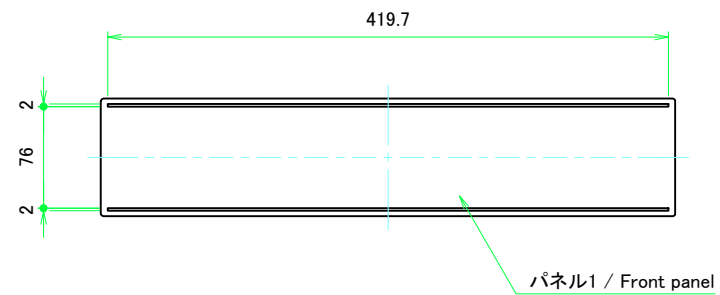
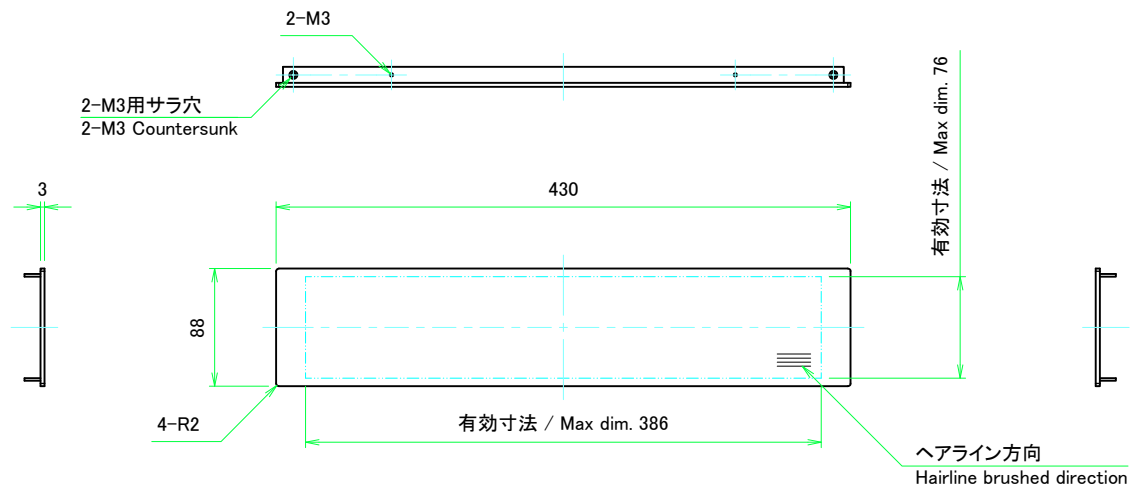

株式会社タカチ電機工業 TAKACHI ELECTRONICS ENCLOSURE CO., LTD.			品名/Title パネル Front panel , Rear panel	尺度/Scale 1:4
承認/Approved 中根	検図/Checked 王	製図/Created 野村	型番/Product number W430 - H88	
			作成日/Date 2017/06/05	4 / 5

天板 / Top cover

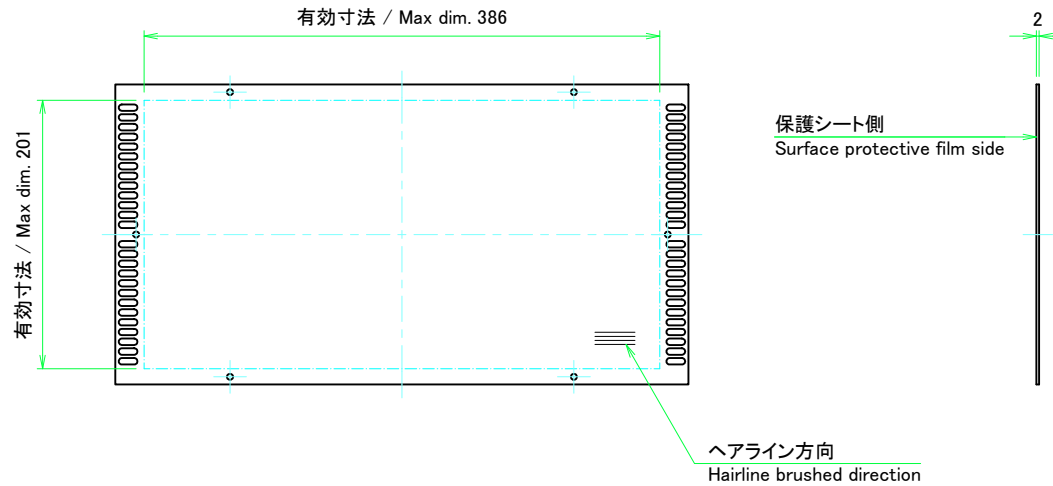

表面 / Front side

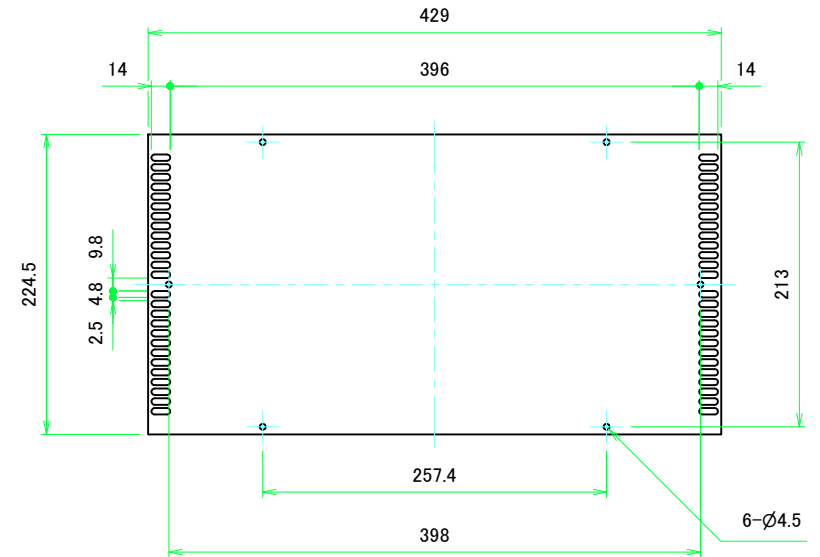

裏面 / Back side

底板 / Bottom cover

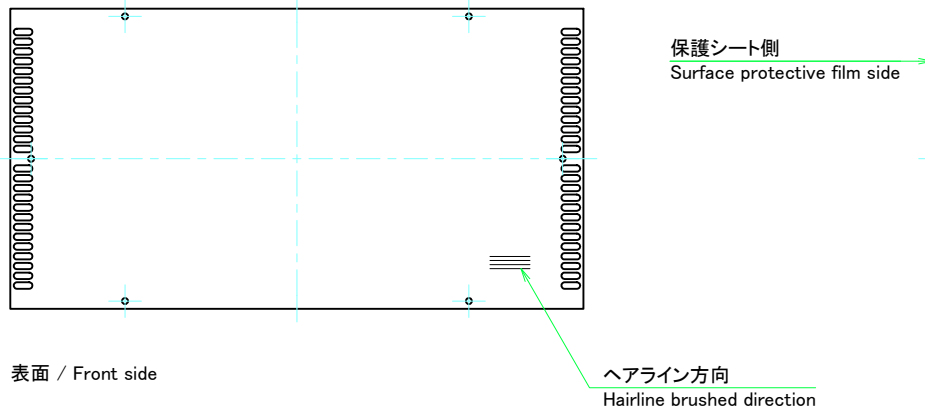

表面 / Front side

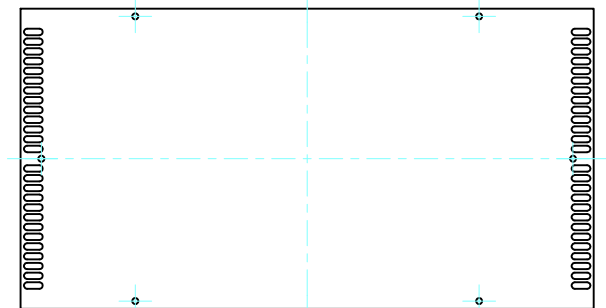

裏面 / Back side

株式会社タカチ電機工業 <small>TAKACHI ELECTRONICS ENCLOSURE CO., LTD.</small>			品名/Title 天底板 Top cover, Bottom cover	尺度/Scale 1:4
承認/Approved	検図/Checked	製図/Created	型番/Product number W430 - D231	
中根	王	野村	作成日/Date 2017/06/05	5 / 5